

# The Norgren Guide to Specifying Pneumatic Actuators

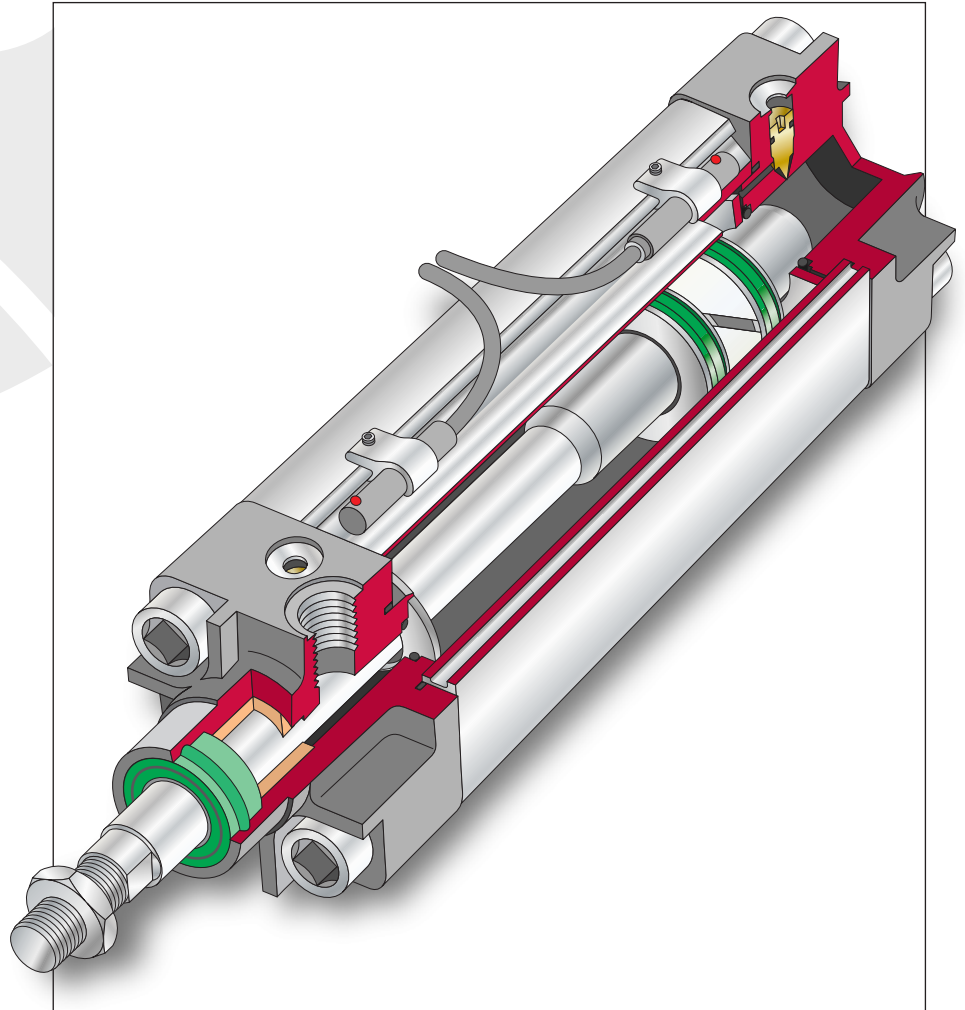

- Design theory
- Applications
- Bore and stroke selection

## CONTENTS

<b>Introduction</b>	<b>5</b>		
<b>Fundamental designs</b>	<b>5</b>		
Single acting cylinders	5		
Double acting cylinders	6		
Magnetic cylinders	6		
Rodless cylinders	6		
Rotary actuators	6		
Clamping cylinders	7		
Bellows	7		
<b>Cylinder sizing for thrust</b>	<b>8</b>		
Useable thrust	8		
Clamping applications	9		
Dynamic applications	9		
Piston rod buckling	9		
Speed control	9		
Increasing speed	12		
Cycle times	12		
Cylinder air consumption	13		
<b>Seals</b>	<b>14</b>		
'O' ring piston seals	14		
Cup seals	15		
'Z' rings	15		
'O' ring barrel seals	15		
Cushion seals	15		
Piston rod seals	15		
Piston rod bellows	15		
Extreme operating temperatures	16		
Wear ring	16		
<b>Cushion design</b>	<b>16</b>		
<b>Shock absorbers</b>	<b>17</b>		
<b>Standards</b>	<b>18</b>		
Non standard dimensions	18		
<b>Types of construction</b>	<b>19</b>		
Sealed for life	19		
Micro cylinders	19		
Round line cylinders	19		
Small bore ISO	19		
Compact cylinders 12-40mm bore	19		
		Serviceable	20
		Light and medium duty	20
		Compact cylinders 50-100mm bore	20
		ISO/VDMA profile	20
		ISO/VDMA (exposed tie rod)	20
		Heavy Duty	20
		<b>Mountings</b>	<b>21</b>
		Rigid mountings	21
		Articulated mountings	21
		<b>Installation</b>	<b>22</b>
		<b>Non rotational guiding</b>	<b>22</b>
		<b>Locking</b>	<b>23</b>
		<b>Rodless cylinders</b>	<b>24</b>
		Rodless cylinder with brake	24
		Integrated valves	24
		Heavy duty rodless cylinder	25
		<b>Cylinder variants</b>	<b>25</b>
		Through rod	25
		Multi position	25
		Tandem	25
		Duplex	26
		Custom piston rod end	26
		Extreme operating temperatures	26
		Special Purpose Actuators	26
		Double stroke cylinders	26
		<b>Positioners and servo cylinders</b>	<b>27</b>
		Open loop applications	27
		Closed loop applications	27
		In line positioners	28
		<b>Servo cylinders</b>	<b>29</b>
		Universal positioner	29
		<b>Hollow piston rod cylinders</b>	<b>30</b>
		<b>Impact cylinders</b>	<b>31</b>
		Principal of operation	31
		Installation	32
		<b>Common terminology variants</b>	<b>32</b>

## LIST OF ILLUSTRATIONS

Adjustable cushion cylinder	6	Non adjustable unit	41
Adjustable shock absorber	42	Non-rotating VDMA	61
Banjo flow regulators	25	'O' Ring section	32
Bellows	14	Offset load bending moment	59
Braking unit	72	Open loop	83
Calculating equivalent mass	43	Out of alignment bearing	58
Closed loop control	84	Piston and rod diameters	15
Compact cylinder	47	PRA/8000/M cylinder	49
Compact guided cylinder	62	Pre-exhaust circuit	29
Conventional flow regulators	24	Precision roller guide	71
Cushion seal	36	Proportional band graph	90
Cycle times	28	Quick exhaust valve section	27
Cylinder installation arrangements	20	RA/8000/M cylinder	50
Detail of sealing strip section	68	Rack and pinion	10
Double acting clamp cylinder	13	Rigid mounting styles	54
Double acting non cushioned cylinder	4	Rod bellows	38
Double rack and pinion	11	Rod/wiper seal	37
Double stroke (fixed carriage design)	81	Rodless cylinder	8
Duplex cylinder	79	Rodless cylinder mountings	74
Effective length, centrally mounted cylinder	19	Rotary vane	9
Effective length, rear mounted cylinder	18	Round line cylinders	45
Energy graph	94	Section of a 'Z' ring	34
Energy ratings	92	Section of a cup seal	33
External cushioned circuit	40	Section of barrel seal	35
External guide	70	Section of Lintra	67
Fixed cushion cylinder	5	Sequence of cushioning	39
Fixed range positioner	85	Serviceable compact	48
Four pillar frame	96	Single acting clamp cylinder	12
Full and restricted port aperture	22	Single acting cylinder	2
Heavy duty cylinder	51	Single acting cylinder with no spring, push and pull	3
Heavy duty rodless cylinder	75	Slide unit	65
Hollow rod cylinder	91	Speed graph	26
Impact cylinder and valve	93	Speed/pressure graph	23
Integrated valve	73	Swivel mounting styles	55
Internal guide	69	Table of consumption	30
ISO guide block	63	Table of thrust and pulls, single acting cylinders	16
ISO guide block with locking units	64	Table of thrust and pulls, double acting cylinders	17
ISO RM/8000 series	46	Tandem cylinder	78
Locking unit	66	Three stages of operation	95
Long stroke	57	Three thread types	80
M/29000 detail	87	Through rod	76
M/30000 detail	86	Twin stroke principle	82
Magnetic cylinder	7	Two cylinder multi position	77
Main components of a cylinder	1	Types of seals	31
Maximum stroke length	21	Universal positioner	88
Micro cylinder	44	Weight of cylinder	60
Mountings for ISO/VDMA cylinders	53	Weight on the end of the rod	56
Mountings for small bore ISO cylinders	52	Zero adjustment graph	89

## INTRODUCTION

Pneumatic actuators, of which cylinders are the most common, are the devices providing power and movement to automated systems, machines and processes. A pneumatic cylinder is a simple, low cost, easy to install device that is ideal for producing powerful linear movement over a wide range of velocities, and can be stalled without causing internal damage. Adverse conditions can be easily tolerated such as high humidity, dry and dusty environments and repetitive cleandown with high pressure hoses.

The diameter or bore of a cylinder determines the maximum force that it can exert and the stroke determines the maximum linear movement that it can produce. Cylinders are designed to work at different maximum pressures up to 16 bar. The pressure actually supplied to a cylinder will normally be reduced through a pressure regulator to control the thrust to a suitable level. As an example of cylinder power, a 40mm bore cylinder working at 6 bar could easily lift an 80kg man.

The basic construction of a typical double acting single rod cylinder is shown in the cut away section (Figure 1), where the component parts can be identified.

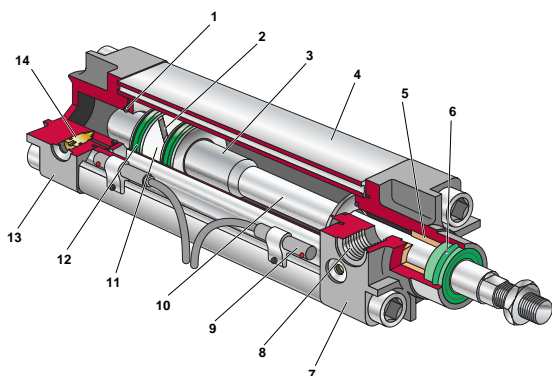

Figure 1: Main components of a cylinder

Key:

- |                      |                                |
|----------------------|--------------------------------|
| 1 Cushion seal       | 8 Front port                   |
| 2 Magnet             | 9 Magnetically operated switch |
| 3 Cushion sleeve     | 10 Piston rod                  |
| 4 Barrel             | 11 Wear ring                   |
| 5 Nose bearing       | 12 Piston seal                 |
| 6 Rod seal and wiper | 13 Rear end cover              |
| 7 Front end cover    | 14 Cushion adjustment screw    |

Pneumatic actuators are made in a wide variety of sizes, styles and types including those giving a semi rotary output. Each major type will be covered in concept.

## FUNDAMENTAL DESIGNS

### SINGLE ACTING CYLINDERS

Single acting cylinders use compressed air for a power stroke in one direction only. The return stroke is effected by a mechanical spring located inside the cylinder. For single acting cylinders with no spring, some external force acting on the piston rod causes its return. Most applications require a single acting cylinder with the spring pushing the piston and rod to the instroked position. For other applications sprung outstroked versions can be selected. Figure 2 shows both types of single acting cylinder.

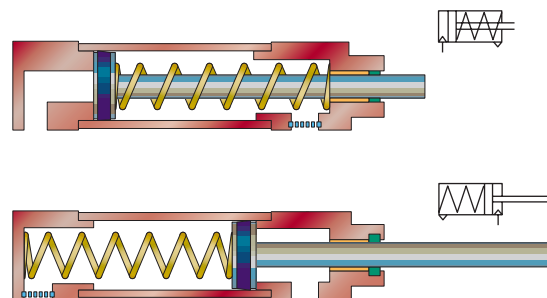

Figure 2: Single acting cylinder

The spring in a single acting cylinder is designed to provide sufficient force to return the piston and rod only. This allows for the optimum efficiency from the available air pressure. Most single acting cylinders are in the small bore and light duty model ranges and are available in a fixed range of stroke sizes. It is not practical to have long stroke or large bore single acting cylinders because of the size and cost of the springs needed. Single acting cylinders with no spring have the full thrust or pull available for performing work. These are often double acting cylinders fitted with a breather filter in the port open to atmosphere. The cylinder can be arranged to have a powered outstroke or a powered instroke (Figure 3).

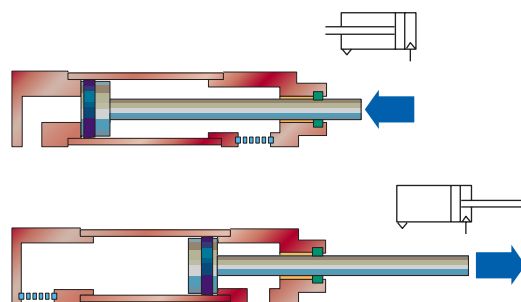

Figure 3: Single acting cylinder with no spring, push and pull

## DOUBLE ACTING CYLINDERS

Double acting cylinders use compressed air to power both the outstroke and instroke. This makes them ideal for pushing and pulling within the same application. Superior speed control is possible with a double acting cylinder, achieved by controlling the exhausting back pressure.

Non cushioned cylinders will make metal to metal contact between the piston and end covers at the extreme ends of stroke. They are suitable for full stroke working only at slow speeds which result in gentle contact at the ends of stroke (Figure 4). For faster speed, external stops with shock absorption are required. These should be positioned to prevent internal contact between the piston and end covers.

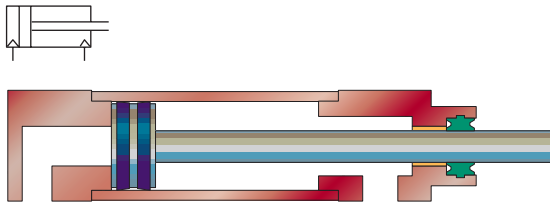

Figure 4: Double acting non cushioned cylinder

Cushioned cylinders have a built in method of shock absorption. Small bore light duty cylinders have fixed cushions which are simply shock absorbing discs fixed to the piston or end cover (Figure 5).

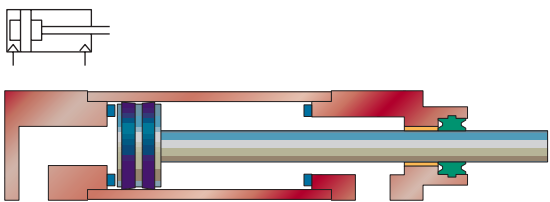

Figure 5: Fixed cushion cylinder

Other cylinders have adjustable cushioning. This progressively slows the piston rod down over the last part of the stroke by controlling the escape of a trapped cushion of air (Figure 6). The cushion action is covered in detail later (Figure 38).

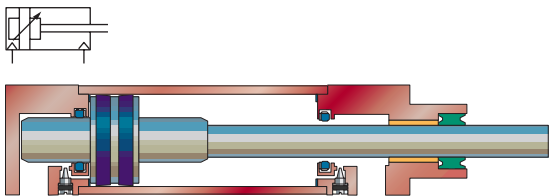

Figure 6: Adjustable cushion cylinder

## MAGNETIC CYLINDERS

Magnetic cylinders have a band of magnetic material around the circumference of the piston and are fitted with a non-magnetic cylinder barrel. The magnetic field can be imagined as the shape of a donut around the barrel. This will travel with the piston as the piston rod moves in and out. By placing

magnetically operated switches on the outside of the barrel, one at each end for example, signals will be received each time the piston rod completes a stroke (Figure 7).

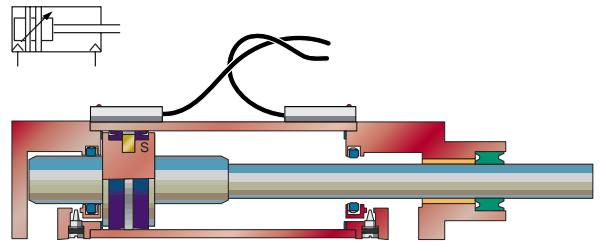

Figure 7: Magnetic cylinder

## RODLESS CYLINDERS

For some applications it is desirable to contain the movement produced by a cylinder within the same overall length taken up by the cylinder body. For example, action across a conveyor belt, or for vertical lifting in spaces with confined headroom. The novel design of a rodless cylinder is ideal in these circumstances. The object to be moved is attached to a carriage running on the side of the cylinder barrel. A slot, the full length of the barrel, allows the carriage to be connected to the piston. Long sealing strips on the inside and outside of the cylinder tube prevent loss of air and ingress of dust. The slot is unsealed only between the lip seals on the piston as it moves backwards and forwards (Figure 8). Direction and speed control is by the same techniques as applied to conventional cylinders.

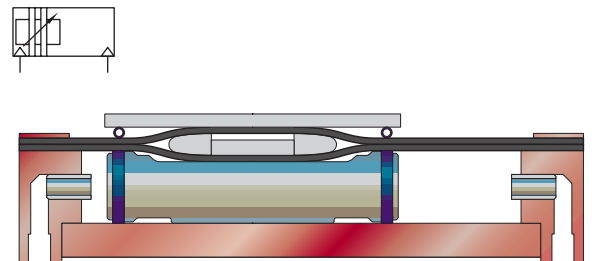

Figure 8: Rodless cylinder

## ROTARY ACTUATORS

There are many applications that require a turning or twisting movement such as turning components over in a drilling jig or providing a wrist action on a pick and place device. Rotary actuators provide angular rotation up to 360°. A typical rotary vane design is shown in (Figure 9).

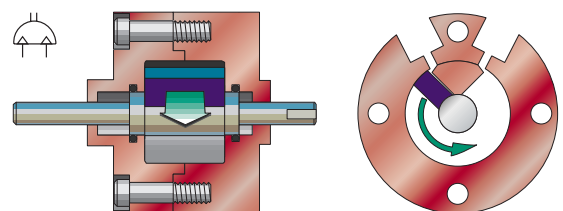

Figure 9: Rotary vane

Another form of rotary actuator is the rack and pinion design. The basic double acting rack and pinion design is shown in (Figure 10). These larger actuators are often used in the process industry to operate quarter turn valves.

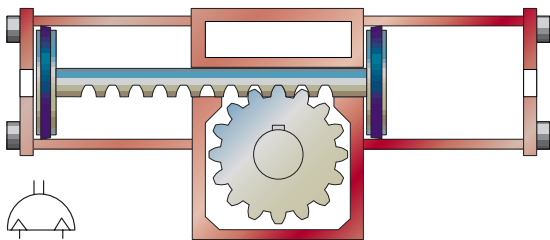

Figure 10: Rack and pinion

The torque output can be doubled by adding a second actuator to drive the same pinion (Figure 11).

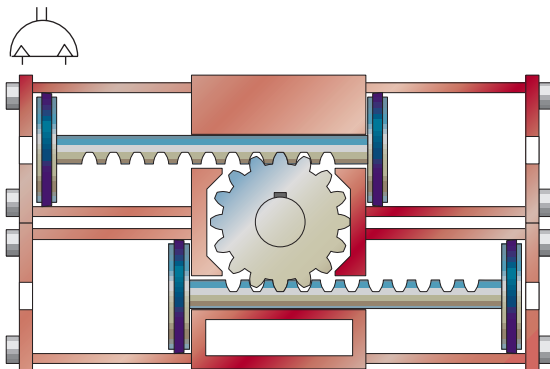

Figure 11: Double rack and pinion

## CLAMPING CYLINDERS

For use in confined spaces where only a short stroke is required these cylinders have a small axial overall dimension for their bore size. They are mostly used in single acting versions (Figure 12), but are also available as double acting through-rod styles (Figure 13). They are usually used in light duty applications.

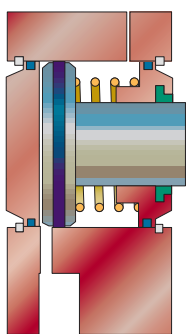
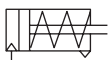

Figure 12:  
Single acting clamp cylinder

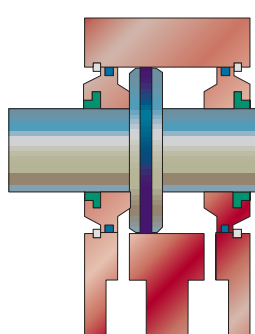

Figure 13:  
Double acting clamp cylinder

## BELLOWS

Bellows are durable single acting concertina like actuators which extend when inflated and are similar to the air suspension units seen on large trucks. They provide powerful short strokes and have all round compliance allowing them to bend in any direction (Figure 14). Single, double and triple convolution types provide a range of strokes with power developed from nominal diameters in the range 70mm to 546mm. Loads varying in angle up to a maximum of 30° from the actuator axis can be accommodated.

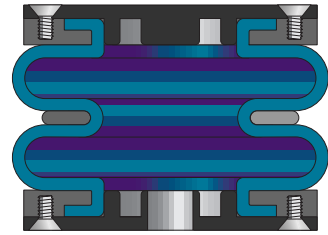

Figure 14: Bellows

These actuators can be used as air springs and are ideal for isolating the vibration of supported loads from the actuators base mounting. To avoid the accumulation of moisture if used with wet air, bellows should be installed with the port facing down, to assist expulsion with the exhaust on each cycle.

**Caution:** The maximum extension and compression of the bellows must be limited by external restraints. The bellows must never be pressurised while unrestrained as it will over extend and the end plate is likely to be blown free and could cause serious injuries. When the bellows are exhausted the load must be prevented from crushing it by means of external stops.

## CYLINDER SIZING FOR THRUST

The theoretical thrust (outstroke) or pull (instroke) of a cylinder is calculated by multiplying the effective area of the piston by the working pressure. The effective area for thrust is the full area of the cylinder bore. The effective area for pull is reduced by the cross section area of the piston rod (Figure 15).

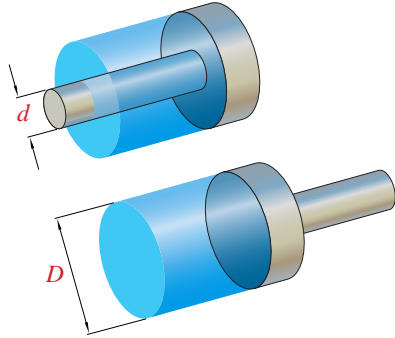

Figure 15: Piston and rod diameters

Current practice specifies bore ( $D$ ) and piston rod diameter ( $d$ ) in millimetres and working pressure ( $P$ ) in bar gauge. In the formula,  $P$  is divided by 10 to express pressure in Newtons per square millimetre (1 bar = 0.1 N/mm<sup>2</sup>)

The theoretical force ( $F$ ) is given by

$$\text{Thrust } F = \frac{\pi D^2 P}{40} \text{ Newtons}$$

$$\text{Pull } F = \frac{\pi(D^2 - d^2)P}{40} \text{ Newtons}$$

Where

$D$  = Cylinder bore in millimetres

$d$  = Piston rod diameter in millimetres

$P$  = Pressure in bar

$F$  = Thrust or Pull in Newtons

Example:

Find the theoretical thrust and pull of a 50mm bore cylinder supplied with a pressure of 8 bar

$$\text{Thrust } F = \frac{\pi 50^2 \cdot 8}{40} = 1571 \text{ Newtons}$$

$$\text{Pull } F = \frac{\pi(50^2 - 20^2) \cdot 8}{40} = 1319 \text{ Newtons}$$

Calculating the thrust or pull of single acting cylinders with a spring is more complicated. The spring force opposing the thrust or pull will progressively increase as more of the stroke is achieved. This must be subtracted to find the theoretical force.

In practice thrust and pull values for double acting and single acting cylinders can be obtained from the catalogue covering the selected cylinder range. These will be given for a particular pressure, usually 6 bar. The values for other pressures can be easily calculated by multiplying by the new pressure divided by 6.

When estimating the relative thrusts of cylinders with different bore sizes, it can be useful to remember that thrust increases with the square of the diameter. In other words if you double the bore you will quadruple the thrust (Figures 16&17).

Cylinder bore mm	Thrust N at 6 bar	Min pull of spring N
10	37	3
12	59	4
16	105	7
20	165	14
25	258	23
32	438	27
40	699	39
50	1102	48
63	1760	67
80	2892	86
100	4583	99

Figure 16: Table of thrust and pulls, single acting cylinders

Cylinder bore mm (inches)	Piston rod diameter mm (inches)	Thrust N at 6 bar	Pull N at 6 bar
8	3	30	25
10	4	47	39
12	6	67	50
16	6	120	103
20	8	188	158
25	10	294	246
32	12	482	414
40	16	753	633
44.45 (1.75)	16	931	810
50	20	1178	989
63	20	1870	1681
76.2 (3)	25	2736	2441
80	25	3015	2721
100	25	4712	4418
125	32	7363	6881
152.4 (6)	(1 1/2)	10944	10260
160	40	12063	11309
200	40	18849	18095
250	50	29452	28274
304.8 (12)	(2 1/4)	43779	42240
320	63	48254	46384
355.6 (14)	(2 1/4)	59588	58049

Figure 17: Table of thrust and pulls, double acting cylinders

## USABLE THRUST

When selecting a cylinder size and suitable operating pressure, an estimation must be made of the actual thrust required. This is then taken as a percentage of the theoretical thrust of a suitably sized cylinder. The percentage chosen will depend on whether the thrust is required at the end of movement as in a clamping application or during movement such as when lifting a load.

## CLAMPING APPLICATIONS

In a clamping application the force is developed as the cylinder stops. This is when the pressure differential across the piston reaches a maximum. The only losses from the theoretical thrust will be those caused by friction. These can be assumed to be acting even after the piston has stopped. As a general rule, make an allowance of 10% for friction. This may be more for very small bore cylinders and less for very large ones.

If the cylinder is operating vertically up or down the mass of any clamping plates will diminish or augment the clamping force.

## DYNAMIC APPLICATIONS

The actual thrust and speed from a moving cylinder are determined by friction and the rate at which air can flow in and out of the cylinder's ports. The thrust or pull developed is divided into two components. One for moving the load, the other for creating a back pressure to help expel the air on the exhausting side of the piston.

For a lightly loaded cylinder, most of the thrust is used to expel the back pressure and will result in a moderately fast speed. This is self limiting however as the faster the speed, the less will be the pressure differential across the piston. This is due to the increasing resistance through the ports, tubing, fittings and valve as the rate of flow increases.

For a heavily loaded cylinder most of the thrust is used to move the load. The exhausting pressure will fall considerably to give a higher pressure differential before movement starts. The acceleration and speed will be determined by the inertia of the load and rate at which the lower back pressure is expelled. A heavy load simply diverts a greater proportion of the power of the cylinder away from creating a back pressure to moving the load. Although the speed for a heavily loaded cylinder is going to be slower it is not unreasonably so, providing the cylinder has been correctly chosen. As a general rule, the estimated thrust requirement should be between 50% and 75% of the theoretical thrust. This should give sufficient back pressure for a wide range of adjustable speed control when fitting flow regulators.

## PISTON ROD BUCKLING

Some applications require very long stroke cylinders. If there is a compressive axial load applied to the piston rod, care must be taken to ensure that the system parameters of length, diameter and load are within the safety limits to prevent buckling.

There was a long standing belief that cylinder stroke lengths were limited to a maximum of 15 times the diameter of the bore. Whilst this gave a general indication of maximum stroke length, it did not take into account mounting support factors. In many instances the nature of the application and the style of mounting to be used allow greater stroke lengths, whilst in others the stroke length is considerably less.

To calculate maximum stroke length the following formula should be used:

$$F_k = \frac{\pi^2 \cdot E \cdot J}{L^2 \cdot S}$$

Where

$F_k$  = Permissible buckling force in Newtons

$E$  = Modulus of Elasticity

$J$  = Moment of Inertia

$L$  = Effective length in millimetres

$S$  = Safety factor, normally 5

One of the elements in this formula, Effective length, needs some explanation.

*Effective length x support factor = MAX STROKE LENGTH*

Figure 18 shows an extended cylinder, with a clevis mounted at the piston rod end and a trunnion mounted at the rear end. The load being moved is rigidly guided. The distance  $L$  is the total length that has the buckling force applied to it. This cylinder mounting arrangement has a support factor of 0.6.

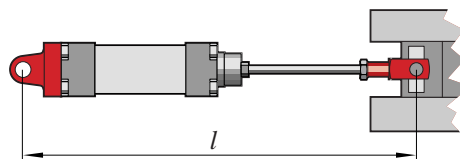

Figure 18: Effective length, rear mounted cylinder

Figure 19 shows a different mounting. The piston rod is directly mounted to the load and the cylinder is centrally trunnion mounted. The load applied is rigidly guided. This configuration has a support factor of 1.3.

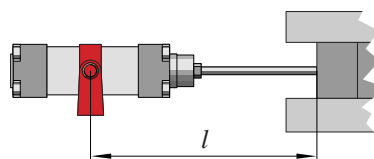

Figure 19: Effective length, centrally mounted cylinder



The effective length and the support factor have a direct effect upon the maximum permissible stroke length. A full table of support factors is shown in Figure 20.

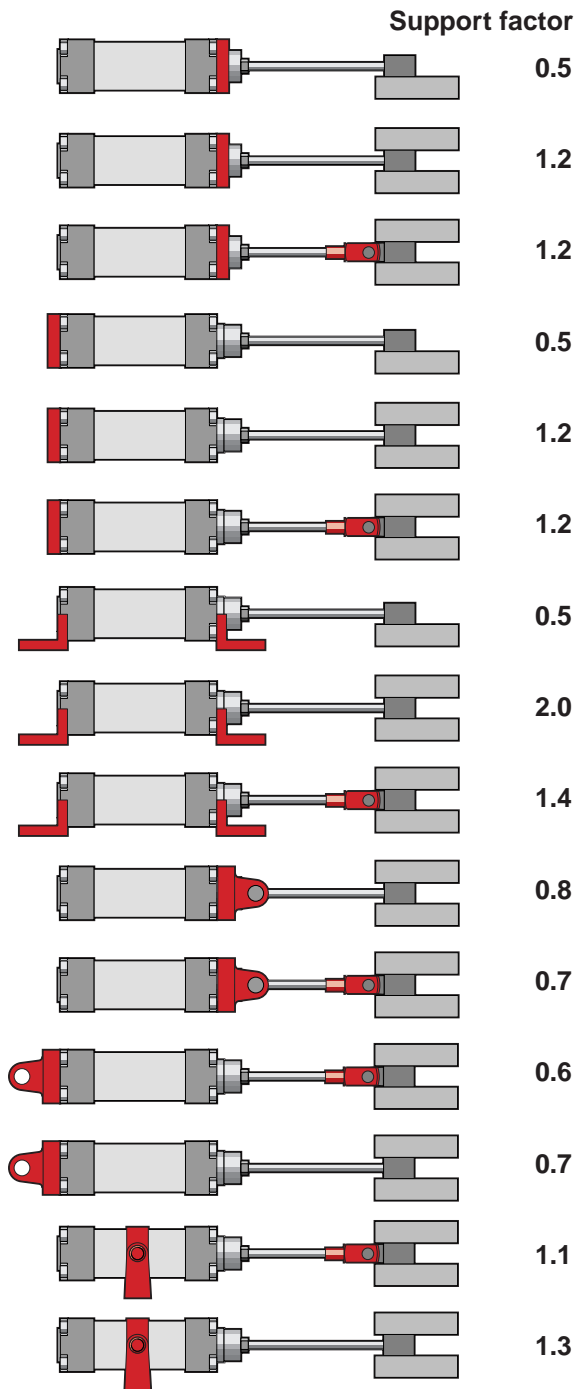

Figure 20: Cylinder installation arrangements

The following graph (Figure 21) is based on the formula mentioned above. It allows calculation of the effective length (and thus maximum stroke length), piston rod diameter or permissible buckling force when two of the three factors are known.

The table of support factors **MUST** be used in conjunction with the graph.

Example:

The requirement is for a cylinder, piston rod diameter 16mm, stroke length 1100mm. The force exerted on the piston rod is

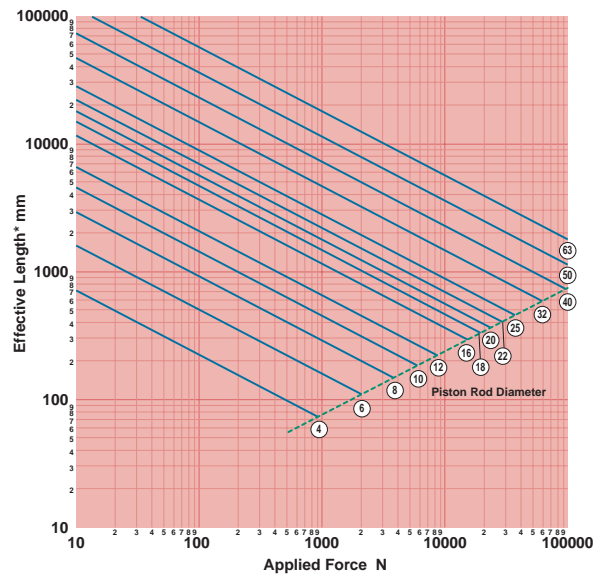

\* Effective length given here must be multiplied by support factor to give Actual Stroke Length

Figure 21: Maximum stroke length

3000N and the mounting style gives a support factor of 2.0. From the horizontal axis  $F = 3000\text{N}$  read vertically up to the intersection point with the 16mm piston rod diameter line. From the point of intersection read horizontally to the left to establish the effective length  $L$ . Multiply this effective length by the support factor 2.0 to give the Maximum Stroke Length for the cylinder.

$$650 \times 2.0 = 1300\text{mm Maximum stroke length.}$$

Therefore a cylinder stroke length of 1100mm is acceptable in this application.

A further requirement is for a stroke length of 1200mm on a cylinder with a piston rod diameter of 12mm. The force exerted on the piston rod is 290N and the cylinder mounting style has a support factor of 0.6.

Using the same method as described previously we find that the effective length  $L = 1180$ .

$$1180 \times 0.6 = 708\text{ Maximum stroke length.}$$

Therefore this cylinder is unsuitable for this application.

There are two solutions:

1. Improve the support factor by changing the mounting arrangement, or
2. Use a larger bore cylinder which has a piston rod diameter of 16mm or above.

In order to avoid undue vibration and shock loading during cushioning, it is recommended that operating speed is regulated and cushion action is as smooth as possible. It should be accepted that cylinder stroke lengths are, in practice, limited by the maximum single length of barrel which is available in raw material form.

## SPEED CONTROL

For many applications, cylinders can be allowed to run at their own maximum natural speed. This results in rapid mechanism movement and quick overall machine cycle times. However, there will be applications where uncontrolled cylinder speed can give rise to shock fatigue, noise and extra wear and tear to the machine components. The factors governing natural piston speed and the techniques for controlling it are covered in this section.

The maximum natural speed of a cylinder is determined by:

- cylinder size
- port size
- inlet and exhaust valve flow
- air pressure
- bore and length of the hoses
- load against which the cylinder is working.

From this natural speed it is possible to either increase speed or as is more often the requirement, reduce it.

First we will look at how the natural speed for any given load can be changed by valve selection. Generally, the smaller the selected valve the slower the cylinder movement. When selecting for a higher speed however, the limiting factor will be the aperture in the cylinder ports (Figure 22). Valves with flow in excess of this limitation will give little or no improvement in cylinder speed. The aperture in the cylinder ports is determined by the design. Robustly constructed cylinders will often be designed with full bore ports. This means that the most restrictive part of the flow path will be the pipe fitting. These cylinders are the type to specify for fast speed applications and would be used with a valve having at least the same size ports as the cylinder. Lighter duty designs, particularly small bore sizes, will have the port aperture much smaller than the port's nominal thread size. This has the desired effect of limiting the speed of the cylinder to prevent it from self destructing through repeated high velocity stroking. The maximum natural speed of these cylinders can often be achieved with a valve that is one or two sizes down from the cylinder port size.

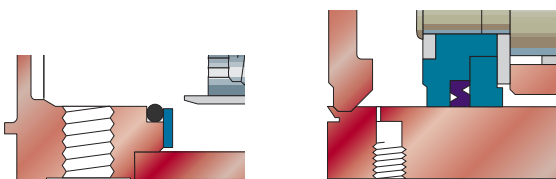

Figure 22: Full and restricted port aperture

Larger bore cylinders are designed with port sizes large enough to allow fast maximum speeds. In many applications however they are required to operate at relatively low speeds. For an application like this, a cylinder can be driven from a valve with smaller sized ports than those of the cylinder.

Once a cylinder/valve combination has been chosen, and the load is known, the natural maximum speed will be dependent on pressure. For an installed cylinder and load, an experiment can be carried out. Connect a control valve that will cause the cylinder to self reciprocate. Then start the system running at a low pressure and gradually increase it. The cylinder will cycle faster and faster until a limiting speed is reached. This is the

optimum pressure for that application. Increase the pressure further and the cylinder starts to slow down. This is caused by too much air entering the cylinder on each stroke. More time is therefore taken to exhaust it and results in a slower cylinder speed.

With any fixed combination of valve, cylinder, pressure and load, it is usually necessary to have adjustable control over the cylinder speed. This is effected with flow regulators, and allows speed to be tuned to the application.

For the majority of applications, best controllability results from uni-directional flow regulators fitted to restrict the flow out of the cylinder and allow free flow in. The regulator fitted to the front port controls the outstroke speed and the one fitted to the rear port controls the instroke speed. Speed is regulated by controlling the flow of air to exhaust which maintains a higher back pressure. The higher the back pressure the more constant the velocity against variations in load, friction and driving force. On the other side of the piston full power driving pressure is quickly reached. Many flow regulators are designed specifically for this convention.

The graph below (Figure 23), shows the behaviour of pressure and speed during the stroke of a typical cylinder fitted with flow regulators.

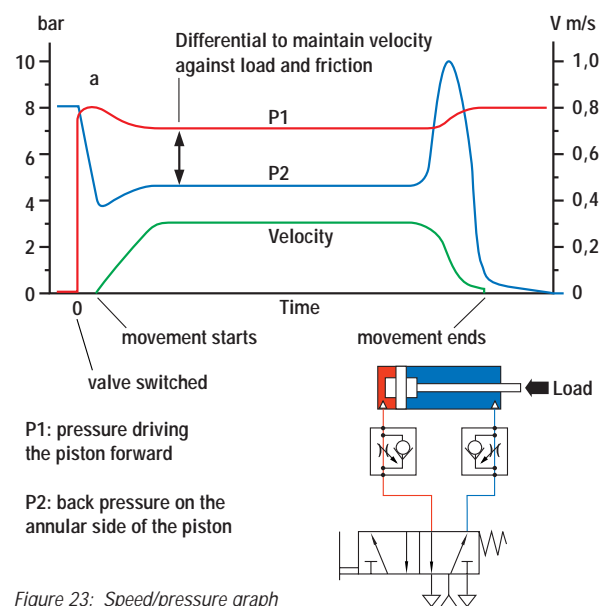

Figure 23: Speed/pressure graph

If speed is controlled by fitting uni-directional flow regulators the other way round, velocity will not be as constant or as controllable. The back pressure will quickly exhaust and the restricted flow on the other side of the piston will slowly build to just enough pressure differential to cause movement. Precise speeds are difficult to adjust as the variables in load and friction represent a higher percentage of the total load. Also, for fast speeds on adjustable cushion types the cushioning will be less effective. For very slow speeds and light loads the movement can be jerky. It is caused by the difference between static and dynamic friction. Pressure builds up to break the piston out of static friction then the lower dynamic friction allows it to accelerate. The restricted flow cannot keep up with it so the pressure drops and the piston stops. The sequence is then repeated.

There are however applications that require the unconventional restriction of flow into a cylinder for speed control and will be acceptable for moderate and fast speed settings. One example is the power stroke of a single acting cylinder where there is no back pressure side to control. Another example is a special case for a double acting cylinder, which has the back pressure side pre-exhausted. A flow regulator controlling the back pressure will have little effect as the back pressure starts at atmosphere and has to be built by the stroke of the cylinder. A further example is the control of some small bore double acting cylinders. With conventional flow control the piston rod gives a characteristic leap forward at the beginning of the outstroke. This is due to the relatively large diameter of the rod to bore ratio and therefore large differential area across the piston. The leap forward intensifies the exhausting pressure to balance the forces before speed control is effective. This problem is solved by regulating the flow in to the cylinder.

The most versatile type of adjustable flow regulator is the uni-directional, line mounted model (Figure 24).

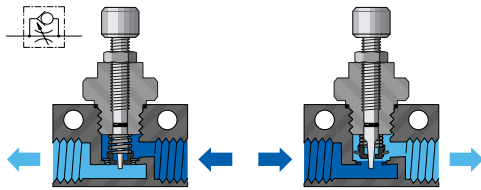

Figure 24: Conventional flow regulators

The line mounted flow regulator can be fitted at any position in the line between the valve and cylinder ports determined by the application. It can be fitted either way round to suit conventional exhaust or special inlet regulation requirements. It consists of a screw with a tapered needle end. As the taper is screwed further into the orifice, so flow is increasingly restricted. When flow is reversed, the orifice disc which also forms a non return valve, lifts to allow unrestricted flow.

A popular alternative design is the elbow banjo flow regulator (Figure 25). This regulator is designed to fit directly in to the cylinder port, so placing adjustment at the appropriate cylinder end. It gives conventional flow restriction out of the cylinder and free flow in.

As an approximate guide, the graph (Figure 26), shows the likely maximum speeds that can be achieved with typical combinations of valve Cv and cylinder bore against percentage loading.

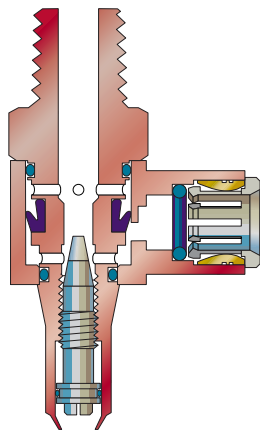

Figure 25: Banjo flow regs

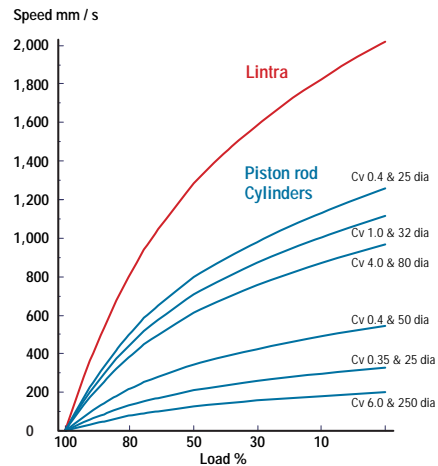

Figure 26: Speed graph

## INCREASING SPEED

In some applications cylinder speed can be improved by using a quick exhaust valve.

This allows air to flow from the control valve in to the cylinder past a poppet lip seal (Figure 27). When the control valve is operated to reverse the cylinder, the lower pressure on the valve side of the poppet seal allows it to rapidly open exhausting the air in the cylinder through the large exhaust port and silencer. Because this bypasses the tubing and main control valve, the flow is faster and the back pressure is less. This allows the cylinder to accelerate more rapidly. Increases of up to 50% of the cylinder's natural speed can be achieved depending on the cylinder type and loading. A quick exhaust valve must be fitted directly to the cylinder port. If high speed is required in both directions, both of the cylinder's ports must be fitted with quick exhaust valves.

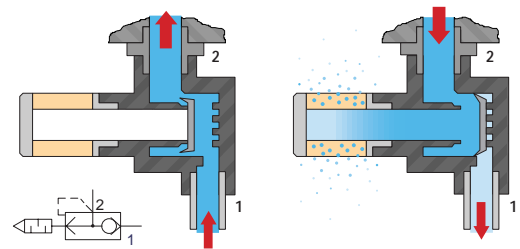

Figure 27: Quick exhaust valve section

**Warning:** A cylinder's in built cushioning will be less effective when used in conjunction with a quick exhaust valve. This is due to the increased speed and lower back pressure. External cushioning is likely to be required.

## CYCLE TIMES

For estimating the likely cycle time of a cylinder in an application, it is necessary to take into account the response time of the valve and cylinder in combination.

The table of cycle times (Figure 28), are for double acting cylinders with a 150mm stroke. They perform one cycle

(outstroke and instroke) controlled by 5/2 solenoid/spring valves. Connection is with a 6-bar pressure supply and 1m of tubing between valve and cylinder. The piston rod is not loaded. Another way of increasing the speed of a cylinder is to pre-exhaust it. This involves using a separate valve for each end of the cylinder (Figure 29). The pressurised end of the cylinder is first exhausted so there is no back pressure. Then the valve on the other end is operated to drive the piston.

Bore	Valve ports	Cv	Time m secs
20	1/8	0.3	225
50	1/8	0.4	700
63	1/4	1.0	525
100	1/4	1.0	1100
160	1/2	3.5	950
200	1/2	3.5	1560
200	1	7.8	650
320	1	7.8	1280

Figure 28: Cycle times

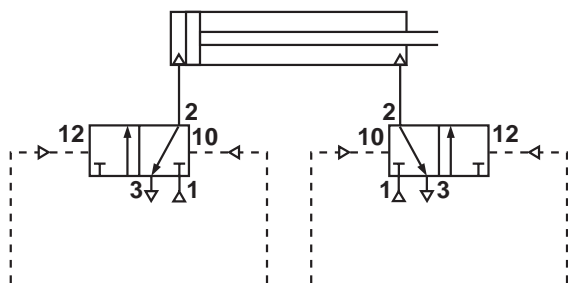

Figure 29: Pre-exhaust circuit

This technique can result in some very fast speeds due to the higher pressure differential across the piston. It is the basis of a control used in high speed rodless cylinder applications producing up to 20 metres/second and is also the basis of the special Impact cylinder.

**Warning:** A cylinder's in built cushioning will be less effective when the cylinder is used pre exhausted. External cushioning is likely to be required.

## CYLINDER AIR CONSUMPTION

The need to calculate the consumption of a cylinder is most often for estimating the total consumption of an application. There are two parts to the air consumption of a cylinder. One is the volume displaced by the piston multiplied by the absolute working pressure. The other is the unswept volume such as cavities in the end cover and piston, the cylinder ports, tubing and valve cavities, all multiplied by the gauge pressure. The unswept part is likely to be a small percentage and will vary with individual installations. A general allowance of around 5% can be added to cover this.

For a double acting cylinder the volume of free air displaced by the piston in one complete cycle will be:

$$\text{Push stroke } V = \frac{\pi D^2 \cdot S \cdot (P_s + P_a)}{4} \cdot 10^{-6}$$

$$\text{Pull stroke } V = \frac{\pi (D^2 - d^2) \cdot S \cdot (P_s + P_a)}{4} \cdot 10^{-6}$$

Where  $V$  = volume in  $\text{dm}^3$  free air

$D$  = cylinder bore mm

$d$  = rod diameter mm

$S$  = stroke mm

$P_s$  = supply gauge pressure (bar gauge)

$P_a$  = atmospheric pressure (assumed to be 1 bar absolute)

If a cylinder is part of an automatic system, its average consumption rate in  $\text{dm}^3/\text{s}$  free air per cycle of the system can be found. Multiply the consumption of one cycle by the number of cycles of the cylinder per cycle of the system, then divide by the system cycle time in seconds.

To estimate the total average air consumption of a pneumatic system carry out the above procedure for each cylinder in the system. Add these values together and add 5%.

It is important to understand that the instantaneous flow requirement for a system will be higher than the average and in some cases very much higher.

For example, a machine has a 2 minute cycle time and is working at a line pressure of 8 bar. It has a large cylinder (200mm bore and 1000mm stroke) which outstrokes and instrokes once, consuming 554  $\text{dm}^3$  free air in each machine cycle.

Over the 2 minute machine cycle time this is an average consumption of 4.6  $\text{dm}^3/\text{s}$  free air. Consider two cases for this machine.

In case (1) it takes 30 seconds for the cylinder to complete one cycle and is dormant for 90 seconds. The average flow it requires per cycle of the machine is still 4.6  $\text{dm}^3/\text{s}$  free air.

In case (2) it completes one cycle in only 6 seconds and is dormant for 114 seconds. The average consumption is the same again, 4.6  $\text{dm}^3/\text{s}$  free air.

In each case it has performed just one cycle in 2 minutes. However if we look at the average dynamic demand (the flow requirement while the cylinder is moving), then in the first case this is 18.5  $\text{dm}^3/\text{s}$  free air and in the second case is 92.4  $\text{dm}^3/\text{s}$  free air. This shows that the air supply capacity to the machine for case (2) must be substantially larger than that which is suitable for case (1) although both consume the same amount of air per machine cycle or per hour.

For a whole machine it is important to ensure that the worst case demand can be satisfied, otherwise there will be air starvation at that time and performance may suffer. To estimate the flow requirement to a machine, first find the average dynamic demand for each cylinder and any other devices consuming air. Plot them on a time based machine function diagram. The worst case point, where overlapping functions are taking place, must be found and the individual demand rates added together. The result will be the minimum capacity the air supply needs to be for the application. If this value is very high and of a relatively short duration, it could be satisfied by a supply with enough capacity for the average machine cycle demand flowing in to a local air receiver. This will take in a charge during instances of low demand and give it out during instances of high demand.

Clearly during the operation of individual cylinders there will be instantaneous peaks above the dynamic average values. These can be complicated to calculate as they are dependent on the load characteristics of each cylinder. In any case they will not last for very long and can usually be ignored.

In general it is good practice to connect pneumatic applications to a supply line with capacity well in excess of their calculated requirement. This will ensure good performance is maintained in the event of future extensions to the machine and the addition of other machines or equipment to the same air line. The table of consumption of free air  $\text{dm}^3/\text{mm}$  of stroke/cycle (Figure 30), will serve as a ready source of data for a typical range of cylinders. Take each figure and multiply by the stroke in mm. For pressures other than 6 bar multiply by the absolute pressure divided by seven.

Bore mm	Rod mm	Push stroke consumption $\text{dm}^3/\text{mm}$ of stroke at 6 bar	Pull stroke consumption $\text{dm}^3/\text{mm}$ of stroke at 6 bar	Combined consumption $\text{dm}^3/\text{mm}$ of stroke/cycle
10	4	0.00054	0.00046	0.00100
12	6	0.00079	0.00065	0.00144
16	6	0.00141	0.00121	0.00262
20	8	0.00220	0.00185	0.00405
25	10	0.00344	0.00289	0.00633
32	12	0.00563	0.00484	0.01047
40	16	0.00880	0.00739	0.01619
50	20	0.01374	0.01155	0.02529
63	20	0.02182	0.01962	0.04144
80	25	0.03519	0.03175	0.06694
100	25	0.05498	0.05154	0.10652
125	32	0.08590	0.08027	0.16617
160	40	0.14074	0.13195	0.27269
200	40	0.21991	0.21112	0.43103
250	50	0.34361	0.32987	0.67348

Figure 30: Table of consumption

## SEALS

There are a variety of seals required within a pneumatic cylinder. Single acting non cushioned cylinders use the least, double acting adjustable cushioned cylinders use the most (Figure 31).

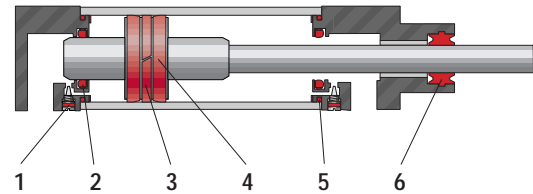

Figure 31: Types of seals

Key:

- |                       |                          |
|-----------------------|--------------------------|
| 1) Cushion screw seal | 4) Piston seal           |
| 2) Cushion seal       | 5) Barrel seal           |
| 3) Wear ring          | 6) Piston rod/wiper seal |

A sliding seal such as fitted to a piston, has to push outwards against the sliding surface with enough force to prevent compressed air from escaping, but keep that force as low as possible to minimise the frictional resistance. This is a difficult trick to perform, since the seal is expected to be pressure tight from zero pressure to 10 bar or more.

There is a large difference between static and dynamic friction. Static friction or break-out friction as it is sometimes called builds up when the piston stops moving. Seals inherently need to exert a force radially outward to maintain a seal. This force gradually squeezes out any lubricants between the seal and the barrel wall and allows the seal to settle in to the fine surface texture. After the piston has been standing for a while, the pressure required to start movement is therefore higher than it would be if it is moved again immediately after stopping. To minimise this effect, seals should have a low radial force and high compliance. High compliance allows the seal to accommodate differences in tolerance of the seal moulding and machined parts without affecting the radial force by a great degree.

Non-lube cylinders are assembled with a coating of grease on the bore of the barrel and the seals. If the compressed air supply is clean and dry this will give the seals a long life without adding oil through an air line lubricator. If however, the compressed air supply contains water droplets, these can gradually wash out the original grease lubricant and shorten the life of the seals. A micro fog air line lubricator can then be fitted to continuously refresh the moving parts with lubricated air.

## 'O' RING PISTON SEALS

A simple 'O'-ring piston seal needs to be a loose fit in the groove, with the outer diameter just in contact with the cylinder bore (Figure 32). When pressure is applied to one side of the piston the 'O'-ring is pushed sideways and outwards to seal the clearance between the outer diameter of the piston and the cylinder wall.

This design will not seal well at low pressure differentials, a minimum of 0.5 bar is usually required. If the seal were designed to be a tight fit in the groove and bore the friction would be too high.

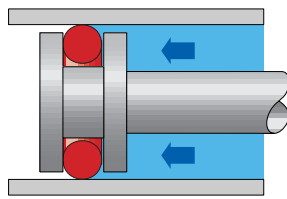

Figure 32: 'O' Ring section

## CUP SEALS

Cup seals are used for piston seals on medium and large bore cylinders. They seal against air pressure in one direction only, therefore in a single acting cylinder, one is required but in a double acting cylinder two are required (Figure 33).

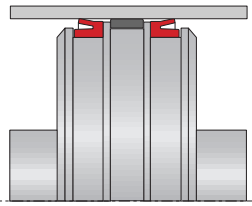

Figure 33: Section of a cup seal

The wide angled lips provide a low radial exertion to reduce the static break out friction. The seal lips have high compliance to allow side loads to be taken by the wear ring. This also allows them to cope with the concentricity and ovality tolerances of the barrel. On larger cylinders it has been known for functional operation to continue even with a slight dent in the barrel.

## Z RINGS

Z Rings are used for piston seals on smaller bore cylinders, these seal against pressure on either side of the piston and take up considerably less space than cup seals (Figure 34). The Z shape acts as a light radial spring providing low radial exertion and high compliance.

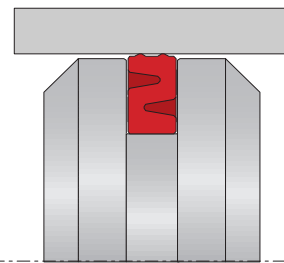

Figure 34: Section of a 'Z' ring

## 'O' RING BARREL SEALS

These are static seals and will be a tight fit in their groove locations (Figure 35).

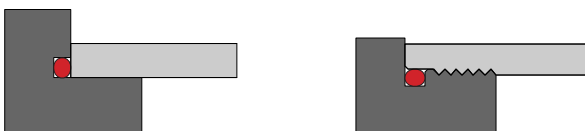

Figure 35: Section of barrel seal

## CUSHION SEALS

These seals perform a dual role of seal and non return valve, sealing on the inside diameter and on the inner face only. This allows sealing in one direction only. In the other direction air flows freely around the outside diameter and other face which have grooves in them. See (Figure 36).

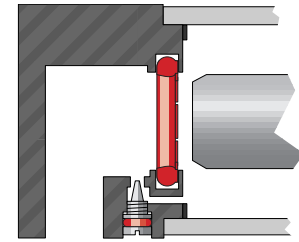

Figure 36: Cushion seal

## PISTON ROD SEALS

These one piece seals serve the dual role of pressure seal and wiper (Figure 37).

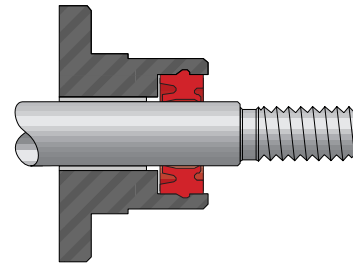

Figure 37: Rod/wiper seal

The outer body of the seal is a pressure tight fit within the bearing housing. The inner lip around the piston rod prevents the escape of compressed air from the clearance between the piston rod and the bearing. The outer lip around the rod cleans the rod each time it is drawn into the cylinder. The cleaning action is very important since abrasive particles can settle and stick to the thin film of lubricant on the rod when it is outstroked. If they are allowed to be drawn back into the cylinder they will considerably shorten the life of the bearing and internal seals. For particularly harsh environments a special seal can be specified. This has a higher pre-load or tighter grip of the rod and is suitable for cylinders that are fitted to the exterior of commercial vehicles, cement plant and automotive welding lines. Such a seal will have a long life where sand and cement dust have settled on the rod and it can cut through plaster drips, frost and ice.

On heavy duty cylinders separate wiper and piston rod seals are used.

## PISTON ROD BELLOWS

As an alternative to special wiper seals a cylinder piston rod can be protected by fitting bellows, also referred to as gaiters. These are made in a variety of styles and materials (Figure 38).

Bellows need to be specified as original equipment, as the cylinder usually requires a slightly longer than standard piston rod to accommodate them when the rod is instroked. This is an ideal solution for applications where the outstroked piston rod surface is likely to be scratched or abraded by falling debris. The bellows need to breath as they concertina in and out, so they are fitted with a breather hole and dust filter. Regular inspection of rod bellows is particularly important. If a tear or split develops the bellows can inhale dust and light weight

particles that will increase the wear on the rod and wiper seal and may become compacted and restrict the stroke of the cylinder.

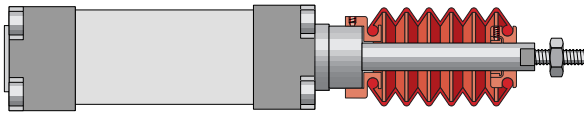

Figure 38: Rod bellows

## EXTREME OPERATING TEMPERATURES

Standard seals are generally recommended for continuous running in the range +2°C to +80°C. Higher temperatures will soften the seals so that they wear more quickly and produce more friction. Lower temperatures will harden the seals which make them brittle and liable to splitting and cracking. For high temperature applications with continuous running at an ambient up to 150°C, cylinders fitted with "Viton" seals should be specified. For continuous running at lower temperature applications down to -20°C, soft low temperature nitrile seals or PTFE seals can be specified. PTFE seals can not be stretched therefore they require a special piston design to allow assembly. When working at low temperatures it is important that the compressed air has been dried to a dewpoint of less than the ambient temperature. If this is not the case water will be condensed from the compressed air and freeze. Ice inside the cylinder will tear the seals and block or restrict small flow paths.

## WEAR RING

A wear ring is an open band fitted around the piston. It is made from a hard plastic material such as a polyamide/ graphite compound. In the event of a high side load, it becomes a bearing that prevents distortion of the seals and protects against scoring of the barrel from the piston.

## CUSHION DESIGN

In a non cushioned cylinder the piston comes to a stop by hitting the end cover. This must dissipate the kinetic energy of the piston and rod, plus the load if it is attached. It is noisy and will fatigue the piston and end cover material, eventually leading to the break down of these components. To prevent this, the piston needs to be cushioned in some way over the final part of stroke. Small light duty cylinders will have less mass in their components and load, therefore fixed cushioning is adequate to solve the problem.

For larger cylinders with more work to do, the piston needs progressively slowing down over the last 20mm of stroke. This is achieved with an adjustable cushioned cylinder.

There are a variety of cushion designs but the principle of operation is the same. The explanation here (Figure 39) is for a type with the cushion seals captive in the end covers (A). The piston is moving right to left at speed towards the rear end cover. Back pressure is flowing freely through the cushion seal.

This flow path is suddenly interrupted when the cushion sleeve enters the cushion seal (B). The exhausting air can only escape through a much smaller path incorporating the adjustable cushion screw with its tapered restrictor. The rapidly moving piston is displacing more air than the cushion screw can cope with so the pressure builds up and cushions the piston. The adjustment allows the right amount of restriction to be set to bring the piston, rod and load to a smooth gentle halt against the end cover (C). If the cushion screw is too severely set the piston may bounce slightly before completing the stroke or not complete the final part of stroke at all.

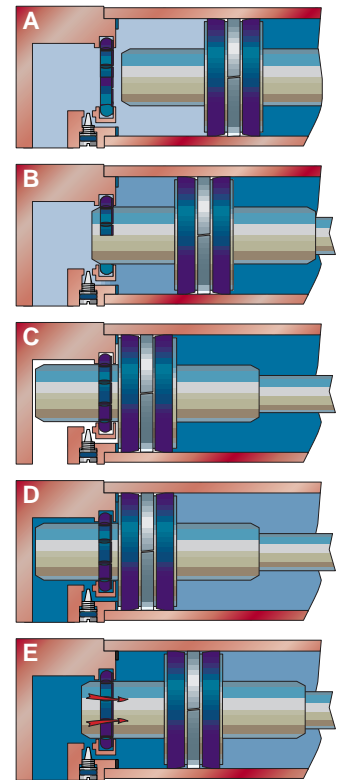

Figure 39: Sequence of cushioning

The cushion seal is a special design with grooves on the outer diameter and flats and grooves on the edge facing the piston. When the sleeve enters the seal the seal is pushed to make contact against the outer edge and inner diameter therefore blocking flow past the sleeve throughout the cushion stroke. The piston is powered in the other direction (D). Compressed air enters the end cover and pushes the seal to contact the inside edge. Air can then flow through the grooves around the outside of the seal to pressurise the piston over the full area (E). This allows normal starting thrust. If it was not for these grooves, full area

pressure build up would be slow, as the only path would be back past the cushion screw.

High mass loads, operated at high speed with long stroke cylinders, may need special circuitry to provide cushioning. See (Figure 40). This circuitry switches in a pre set restrictor to start slowing the cylinder down before the normal cushioning is engaged. Sometimes it is necessary to control a cylinder at a variety of speeds selected at different points in the stroke. For this, valve and flow regulator branches can be set up and switched in to operation either singly or in combination to provide the speed required.

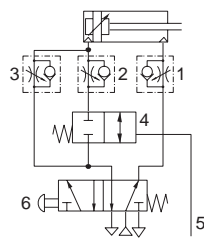

Figure 40:  
External cushioned circuit

## SHOCK ABSORBERS

For more arduous applications involving very high mass and velocity and where particularly smooth deceleration is desired, industrial shock absorbers can be used to supplement or take over a cylinder's built in cushioning. There are two types of unit. One, a range of non adjustable self compensating units in four sizes to cover masses from 0.9 kg to 1130 kg. Two, a range of adjustable units in two sizes to cover masses from 5 kg to 810 kg. A shock absorber has the appearance of a small normally outstroked cylinder. It is mounted in line to oppose the moving mass with it's piston rod protruding beyond the fixed stop position. The mass will contact the shock absorbers rod end and will be decelerated to almost zero velocity before contacting the fixed stop. The shock absorber must be positioned so that it has approximately 1mm of stroke remaining after the fixed stop has been contacted.

The principle of operation of the non adjustable units is based on progressive flow restriction (Figure 41). When a moving mass contacts the piston rod pressure is generated under the piston but the initial resistance is very light. The piston is pushed in easily at first because the oil is displaced from under the piston to the top through a large number of graduated metering orifices. As the stroke progresses fewer and fewer metering orifices are available. This results in smooth linear deceleration at constant pressure of any mass within the specified range for the unit. Oil leakage past the piston rod is prevented by an internal rolling seal which is also the oil displacement accumulator. When the mass is removed the piston rod quickly resets to the outstroke position by means of an internal spring and a non return valve in the piston.

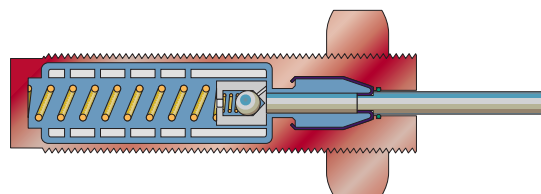

Figure 41: Non adjustable unit

The adjustable units decelerate a moving mass in a similar way to the non adjustable units (Figure 42). There is an internal accumulator containing closed cell elastomer foam for fluid displacement. The return spring is external. The orifice sizes can be regulated by operating an adjusting ring. This allows precise deceleration to be achieved over a wide range of mass and velocity characteristics.

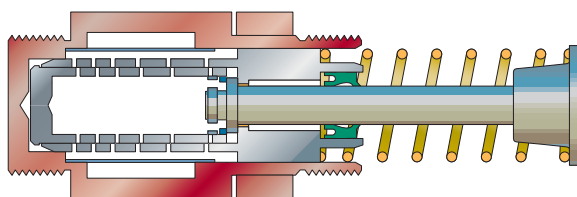

Figure 42: Adjustable shock absorber



Shock absorbers are selected by the equivalent mass in Kg to be decelerated over the stroke of the unit.

Self compensating	Adjustable
0.9 to 10 Kg	5 to 450 Kg
2.3 to 25 Kg	10 to 810 Kg
9 to 136 Kg	
105 to 1130 Kg	

To calculate the equivalent mass use this formula

$$me = \frac{2W_3}{v^2}$$

Where  $me$  = equivalent mass (kg)  
 $W_3$  = total energy  $W_1 + W_2$  (Nm)  
 $W_1$  = kinetic energy =  $\frac{1}{2}m.v^2$  (Nm)  
 $W_2$  = energy of the force =  $F.s$  (Nm)  
 $m$  = mass (Kg)  
 $v$  = velocity (m/s)  
 $F$  = propelling force (N)  
 $s$  = stroke of shock absorber (m)

Example:

A cylinder is moving a mass of 10 kg horizontally with a force of 100N and will contact the shock absorber with a velocity of 1 m/s, (Figure 43). The stroke of the self adjusting unit is a nominal 0.025m.

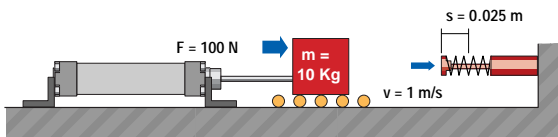

Figure 43: Calculating equivalent mass

$$W_1 = 10 \times 1^2 \div 2 = 5 \text{ Nm}$$

$$W_2 = 100 \times 0.025 = 2.5 \text{ Nm}$$

$$W_3 = 2.5 + 5 = 7.5 \text{ Nm}$$

$$me = 2 \times 7.5 \div 1^2 = 15 \text{ kg}$$

Choose a unit with the 2.3 to 25 Kg range self compensating or 5 to 450 Kg range adjustable from the selection above.

## STANDARDS

ISO 6431 and 6432 standardise the installation dimensions of specified pneumatic cylinders and their fitted mountings. This is to provide easier sourcing and replacement of cylinders with the same bore, stroke and fitted mountings from a wide range of manufacturers. These standards do not include the attachment of the mountings to the cylinder, therefore the mountings from one manufacturer may not fit with the cylinder from another manufacturer.

VDMA 24562 is a refinement of ISO 6431, covering bore sizes from Ø32mm to 320mm, further defining dimensions, particularly tie rod centres and the attachment of mountings to them. A cylinder to this standard is therefore also interchangeable with mountings to this standard.

ISO 6009 relates to the dimensional codes used in manufacturers dimension data sheets for specified cylinders and mountings. The codes cover the main mounting dimensions, envelope dimensions and cylinder fitting dimensions. Many cylinder ranges will include additional mountings beyond the scope of this standard.

## NON STANDARD DIMENSIONS

There are many ranges of cylinder designs not bound by the dimensional restrictions of a standard. This enables users to take advantage of cylinders incorporating the latest innovations in neat and compact designs resulting in smaller overall sizes.

## TYPES OF CONSTRUCTION

### SEALED FOR LIFE

Low cost, light duty, small to medium bore cylinders. The piston is pre-greased for life on assembly and can be operated with non lubricated or lubricated air.

### MICRO CYLINDERS

Very small bore 2.5mm to 6mm diameter, mainly single acting sprung to the instroke (Figure 44). For use in light duty miniature assembly and manufacturing, such as small component jig and mould ejectors, interlocks and test fingers. They are particularly useful in applications that require test probes placed closely together in a high density matrix. For operation in the pressure range 2.5 bar to 7 bar. Typically manufactured with brass end caps and barrel, stainless steel piston rod and nitrile rubber seals.

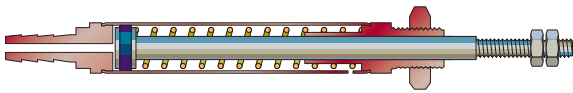

Figure 44: Micro cylinder

### ROUND LINE CYLINDERS

Low cost, light duty, small to medium bore cylinders in the range 8mm to 63mm diameter (Figure 45). The cylinders are assembled by rolling the barrel ends and end covers down to make a pressure tight seal. For operation in the pressure range 1 to 10 bar.

Manufactured with stainless steel (Martensitic) piston rod, aluminium end covers, non magnetic (Austenitic) stainless steel barrel, polyurethane wiper seal, nitrile piston seal and 'O'-rings.

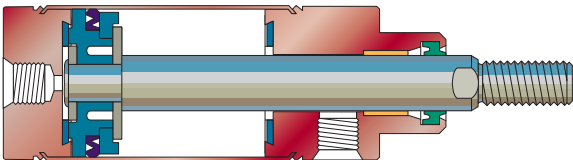

Figure 45: Round line

### SMALL BORE ISO

ISO dimensioned cylinders in the range 10mm to 25mm bore both single acting and double acting (Figure 46). A threaded rear end cover provides a choice of mounting by clamp nut or built in rear eye. For operation with non-lubricated or lubricated air in the pressure range from 1 bar to 10 bar.

Manufactured with stainless steel (Martensitic) piston rod. A choice of fixed or adjustable cushioning is also available.

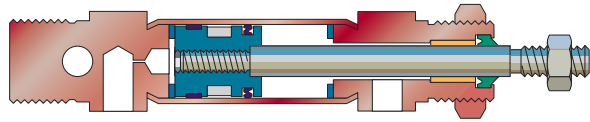

Figure 46: ISO RM/8000 series

### COMPACT CYLINDERS 12 – 40 MM BORE

This design provides a short overall dimension that is approximately one third of the basic length of a comparable ISO design. A magnetic piston is standard on both single and double acting versions (Figure 47). The extruded body has integral grooves for fixing reed switches and magnetic sensors.

Bore sizes range from 12mm to 40mm diameter. For operation with non-lubricated or lubricated air in the pressure range from 1 bar to 10 bar.

Manufactured with stainless steel piston rod, anodised aluminium alloy barrel, nickel plated brass or anodised aluminium alloy end covers, polyurethane seals and acetal wear ring.

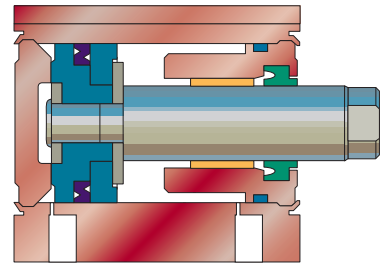

Figure 47: Compact

## SERVICEABLE

### LIGHT AND MEDIUM DUTY

These designs can be dismantled and reassembled by the user. It can be economical to service these cylinders and extend their life by replacing worn seals and regreasing. In the event of damage to part of a cylinder, replacement of component parts can be undertaken. Typical types of construction are:

- screwed barrel and end covers
- end covers retained by circlips
- end covers clamped by tie rods

### COMPACT CYLINDERS 50 – 100MM BORE

Similar to the smaller bore range but with removable front end cover retained by a circlip. This allows for the replacement of seals (Figure 48).

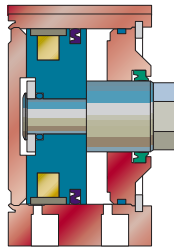

Figure 48: Serviceable compact

### ISO/VDMA PROFILE

Lightweight profile, single and double acting cylinders with integral tie rod construction, in magnetic and non-magnetic versions. Conforming to ISO and VDMA dimensions and with a wide range of mounting options (Figure 49). Adjustable pneumatic cushions on both ends. Bore sizes range from 32mm to 125mm diameter. For operation with non-lubricated or lubricated air in the pressure range 1 to 16 bar. Manufactured with stainless steel piston rod, extruded anodised aluminium profile barrel, die cast aluminium end covers, seals in polyurethane for the piston and rod and nitrile 'O'-rings.

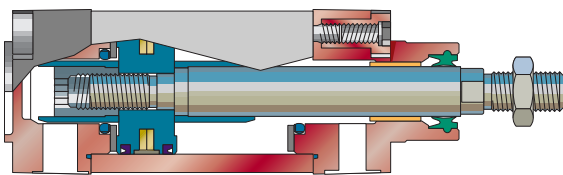

Figure 49: PRA/8000/M cylinder

### ISO/VDMA (EXPOSED TIE ROD)

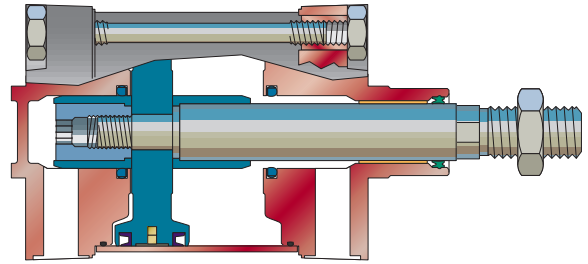

Figure 50: RA/8000/M cylinder

Double acting range from 32mm to 320mm diameter, external tie rod design (Figure 50). For operation with non-lubricated or lubricated air in the pressure range 1 bar to 16 bar (32mm to 200mm bore) and 1 bar to 10 bar (250mm to 320mm bore). Manufactured with stainless steel (Martensitic) piston rod and tie rods, aluminium barrel, die cast aluminium end covers and nitrile rubber seals. Also available in single acting style.

### HEAVY DUTY

Extremely rugged, hard wearing, heavy weight tie rod construction. Featuring large diameter piston rod and long adjustable cushioning. Bore sizes 2" to 12" diameter (Figure 51). For operation with non-lubricated or lubricated air in the pressure range from 1 bar to 10 bar.

Manufactured with stainless steel (Martensitic) piston rod and piston, and cast iron end covers. For units above 3" bore, end covers and piston are cast iron, with a 3 piece construction for the piston. Bearing housings are either integral with the end cover or brass forgings and incorporate a bronze bush bearing. Barrels are normally cold drawn steel with a hard chrome plated bore. This type of cylinder is intended for the most arduous work in mines, quarries, steel plants, foundries and other demanding applications. They are of exceptionally robust construction.

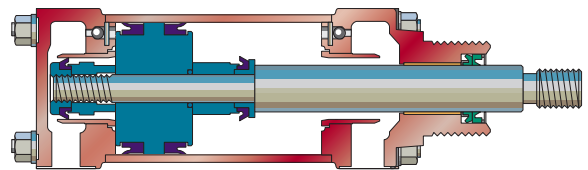

Figure 51: Heavy duty cylinder

## MOUNTINGS

According to the application a cylinder is either going to be rigidly fixed to the structure of a machine or allowed to swivel to form part of a linkage. The points of fixing will be the cylinder body and the piston rod end. In many applications the mechanism attached to the piston rod end will be allowed to hinge in one or more planes. In a few applications however the piston rod end is left free, such as in a simple pushing application. Figures 52 and 53 show a typical range of mountings for small bore cylinders and tie rod style cylinders together with their reference codes.

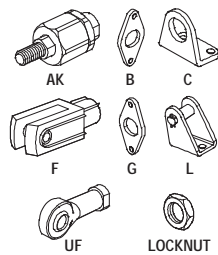

Figure 52: Mountings for small bore ISO cylinders

## ARTICULATED MOUNTINGS

If the cylinder is forming part of a linkage, then it must be free to swivel in one or more planes at the mounting point. Different degrees of balance can be achieved for the cylinder and load system by choosing between rear hinge, front clevis and central trunnion. A front hinge, clevis or universal eye allows swivelling attachments at the end of the piston rod (Figure 55).

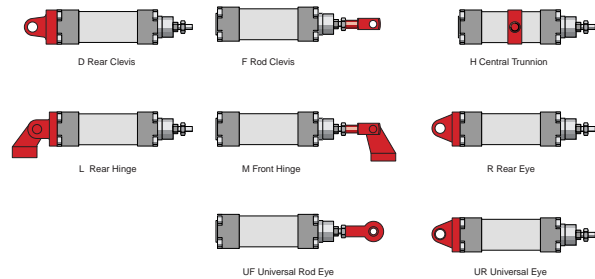

Figure 55: Swivel mounting styles

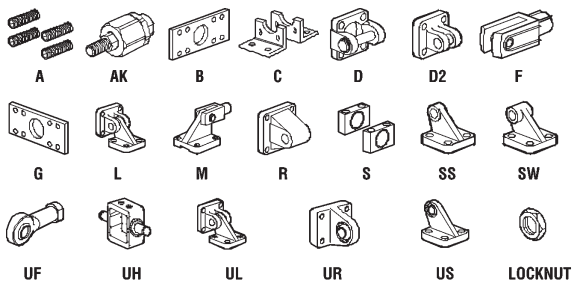

Figure 53: Mountings for ISO/VDMA cylinders

## RIGID MOUNTINGS

A cylinder can be rigidly fixed by side mountings, or front or rear flange plates (Figure 54). Alternatively, if the cylinder has a thread on the front or rear end cover, it can be clamped to a structure with a locknut.

Tie rod cylinders can be fitted with tie rod extensions for fixing through a flat plate.

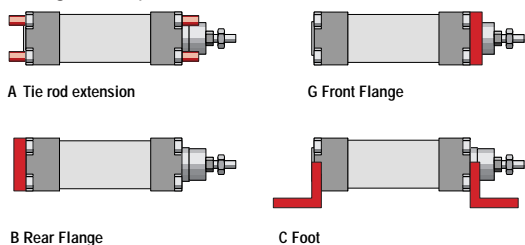

Figure 54: Rigid mounting styles

## INSTALLATION

The mechanics of cylinder installations will vary considerably with their application. A cylinder should be installed so that side loads on the piston rod bearing are reduced to an absolute minimum or eliminated entirely. A side load is a force component acting laterally across the axis of the bearing. The illustrations show five typical situations that will produce a side load on the piston rod bearing and their possible solutions.

1. Avoid attaching an unsupported load to the piston rod (Figure 56a). Wherever possible support the load on slide or roller guides (Figure 56b).

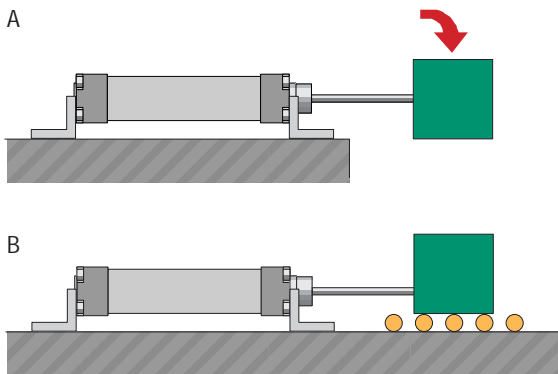

Figure 56: Weight on the end of the rod

2. The weight of a long outstroked piston rod alone can produce a high bending moment (Figure 57a). It may be possible to hang the rod end from a roller track (Figure 57b).

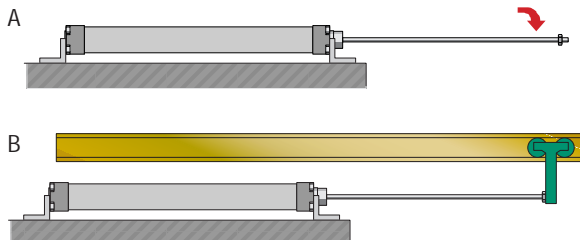

Figure 57: Long stroke

3. Misalignment of the cylinder and a guided load can easily jam the cylinder completely (Figure 58a). Installation of a front fork and slot will eliminate this type of side load (Figure 58b).

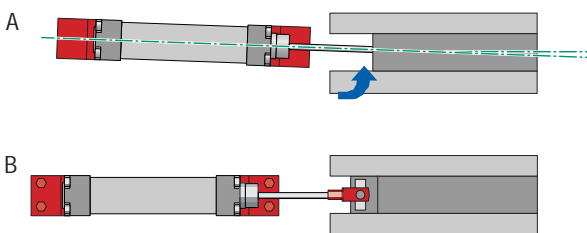

Figure 58: Out of alignment bearing

4. An offset load is a common source of bending moment acting on the end of a piston rod (Figure 59a). Install external heavy duty bearings to relieve the side load on the cylinder bearing (Figure 59b).

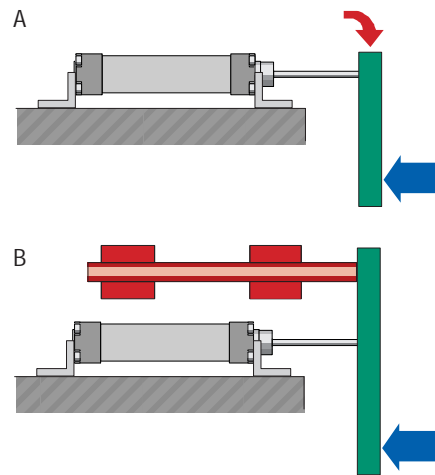

Figure 59: Offset load bending moment

5. A horizontally mounted rear hinged cylinder will have the weight of the cylinder body creating a bending moment (Figure 60a). It would be better if a central trunnion were fitted at the point of balance (Figure 60b). Side loads can rarely be eliminated completely, but by employing good engineering practice they can be reduced to an acceptable level, well within the design parameters of the cylinder. This will give a long reliable life.

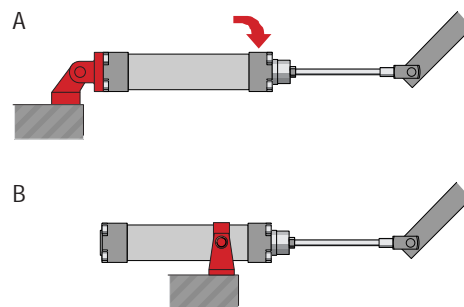

Figure 60: Weight of cylinder

## NON ROTATIONAL GUIDING

There are many applications where loads attached to the piston rod end need guiding simply to maintain orientation. As an example of this, consider a gripper unit attached to the end of an unguided piston rod for the purpose of picking up a rectangular component. The complete gripper assembly could become partially rotated so that the gripper fingers collide with the component they were supposed to pick up. To solve this problem there are a variety of designs providing built in or add on guiding. For Compact, small bore ISO 6432 and ISO/VDMA Ø32 to 100mm bore cylinders there is a version with a non rotating piston rod. This has continuous flats running the length of the rod and runs in a bearing with a matching shape (Figure 61). This design is intended to prevent light torsional loads only. Higher torsion will cause more rapid wear of

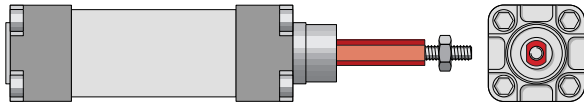

Figure 61: Non-rotating VDMA

the bearing and when the rod is outstroked twist in the rod can occur. Within the Compact range there is also a guided model which incorporates twin guide bars running in bearings within the extruded cylinder body (Figure 62).

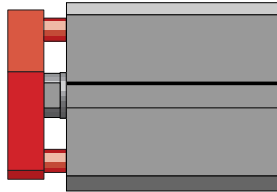

Figure 62: Compact guided

For higher loads there is a choice of add on guide block units with slide or roller guides. These provide non rotational guiding and greater support against bending moments (Figure 63).

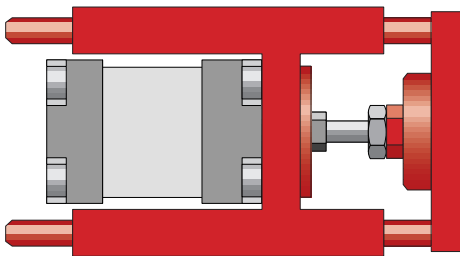

Figure 63: ISO guide block

For low friction running and the best support against bending and torsional loads, use the version with twin roller guides (Figure 64). These units can be fitted with twin passive or active locking cartridges.

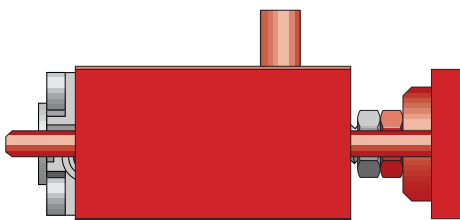

Figure 64: ISO guide block with locking units

For precise actuation, linear slide units incorporate high quality slide bearings which provide exceptional torsional rigidity with a twin through-rod layout (Figure 65). These units also offer a magnetic piston and a choice of port connection positions.

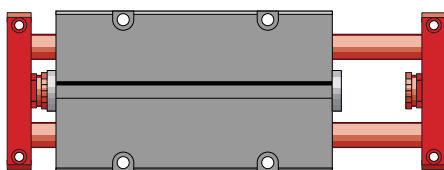

Figure 65: Slide unit

## LOCKING

For safety in the event of air failure or as part of a machine sequence, a cylinder may be required to stop and hold a load at any position in the stroke. To satisfy this requirement, a passive or active piston rod locking unit can be used (Figure 66). A range of these add on units is designed to suit ISO and ISO/VDMA cylinders from 12mm to 125mm bore.

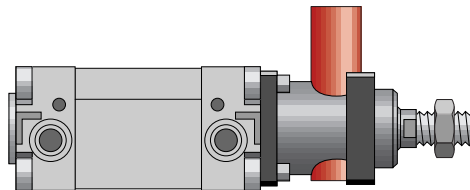

Figure 66: Locking unit

The passive units contain a normally-on spring activated lock which requires air pressure to release it. The active units contain a normally sprung off lock which is activated by the application of air pressure. In both types, the lock clamps the piston rod against loads up to the full rating for the cylinder. The passive locking unit can be connected with a permanent pressure supply. This will hold the brake off and the cylinder will stroke normally. In the event of a failure of the supply, a fail to the safe lock-on position occurs. This will lock the piston rod at any intermediate position and support the load. Part of a machine sequence may consist of a long stroke cylinder that is required to progressively move a component under a tool where an assembly operation is repeated in several different locations. At each location the position of the piston rod must be locked to prevent it from drifting against varying load conditions. If an active lock cylinder is used, each time it stops at a location, the air supply to the locking unit can then be applied through a suitable valve and the piston rod will be locked. Twin active or passive locking cartridges can be added to the roller guide unit where the locking action is applied to the guide bars (Figure 64).

**Note:** These units should not be used to achieve a braking action on the piston rod. They are designed to give a locking function only.

## RODLESS CYLINDERS

This design is a departure from conventional cylinder design in that the actuation is produced by a carriage moving along the side of the barrel. This is a huge advantage for many applications as it allows movement to take place within the length of the cylinder body. For example when lifting in areas with restricted head room or for cutting strip material drawn from a roll where the cylinder can simply straddle the strip.

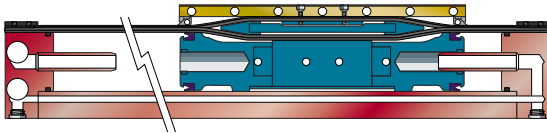

Figure 67: Section of lintra

The barrel has a slot along its full length to allow the piston to connect with and drive the external carriage (Figure 67). The slot is sealed against pressure and dust with inner and outer self retaining sealing strips (Figure 68). These are continuously parted and resealed by the piston within its own length as it is driven backwards and forwards. The slot is only ever unsealed in the unpressurised space between the main piston seals. Bore sizes range from 16mm to 80mm with maximum strokes up to 8.5 metres depending on bore. Adjustable cushioning is standard, comprising cushion sleeves built in to the end covers and cushion seals carried by the piston. One of the two end covers can contain an extra port. This is an alternative to the port in the other end cover, and provides the option to make both port connections to one end.



Figure 68: Detail of sealing strip section

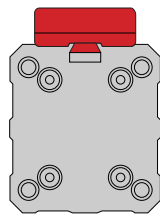

Figure 69: Internal guide

Magnetic versions can have sensors fixed anywhere in grooves running the length of the cylinder barrel. Direction and speed control is as for conventional cylinders. The lightweight extruded cylinder barrel is strong and rigid and can be used as an engineering beam.

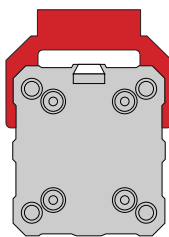

Figure 70: External guide

The internally guided carriage is suitable for light duty applications (Figure 69). For those more demanding, the externally guided carriage provides a long bearing length making use of the 'V' slots extruded in the barrel (Figure 70). This option allows high axial and radial loads to be applied. The guides contain durable plastic wear strips and are adjustable.

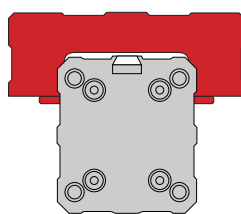

Figure 71: Precision roller guide

Wipers are fitted to remove particles from the surface of the guides. For precision conditions, roller guides can be specified (Figure 71).

## RODLESS CYLINDER WITH BRAKE

For holding the carriage firmly in any position against a fixed or variable load, versions with a passive or active brake can be used. The passive brake is held off by applied air pressure and clamped on by a spring. The active brake is held off by a spring and clamped on by the application of air pressure (Figure 72). Braking is achieved through an asbestos free brake pad acting on a stainless steel strip. This can also be used for locking the drive carriage in varying positions.

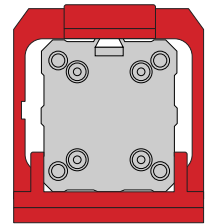

Figure 72: Braking unit

## INTEGRATED VALVES

For convenience and a compact layout, a version can be used which has the end covers fitted with built in 3/2 solenoid valves (Figure 73). These can be used where fast response is required on a remotely sited unit.

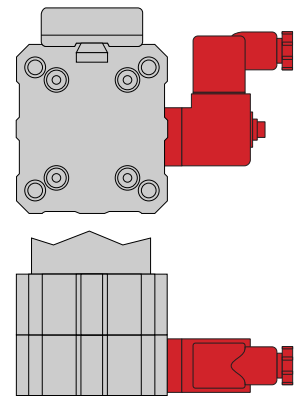

Figure 73: Integrated valve

## MOUNTINGS

A variety of mounting styles for fixing the cylinder body and load are shown (Figure 74). Foot mountings style 'C' for securing the cylinder at the end covers.

Carriage mounting plate style 'UV' for fixing to loads suspended below the cylinder or for mounting the carriage to a static construction and allowing the cylinder body to move. Centre support style 'V' for fixing the cylinder body at mid span to provide extra rigidity. More than one pair can be used spaced at suitable intervals.

Swinging bridge style 'S' for mounting loads to the carriage that need some angular movement. Up to 8° either side of vertical can be accommodated in the axis of the cylinder.

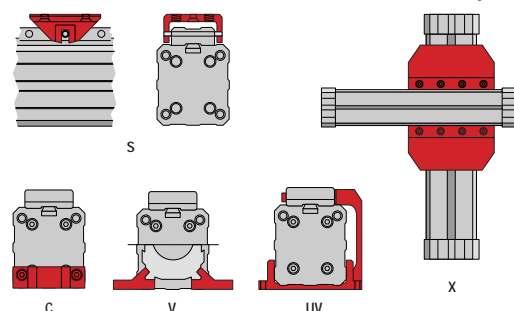

Figure 74: Rodless cylinder mountings

A right angle mounting allows the carriages of two rodless cylinders to be joined to provide movement in two planes. Other mounting arrangements not illustrated include, a secondary free running carriage style 'W' which can be fixed to the opposite side of the cylinder. This can be connected to the main carriage by a side mounting plate style 'UW'. Also an end plate kit for mounting shock absorbers.

## HEAVY DUTY RODLESS CYLINDER

For applications requiring precision movement of heavy loads. This cylinder range uses a rigid aluminium profile and precision linear ball bearing guides. Adjustable buffer end stops are standard and there is a built in mounting provision for adding two pairs of shock absorbers to the carriage (Figure 75). Integral conduit allows cable runs to magnetic position sensors. Fixing is simplified by using the T slots running the length of the profile. A variety of installation arrangements are possible including beam and cantilever applications.

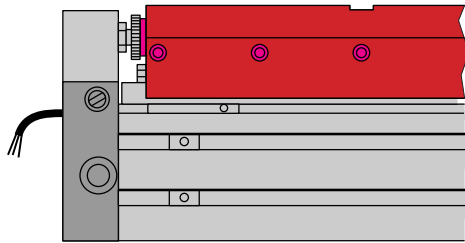

Figure 75: Heavy duty rodless cylinder

## CYLINDER VARIANTS

There are a number of variations that apply to certain cylinder ranges and these can be chosen for special applications.

### THROUGH ROD

This arrangement effectively has a continuous piston rod running through both end covers (Figure 76). This provides two widely spaced piston rod bearings giving a more rigid construction and better stability against side loads. The through rod can be used to advantage in certain applications. One end could be performing work while the other is carrying cams to operate limit switches or some mechanism. The effective area of the piston is the same on both sides. This can be exploited in some applications where pressure equalisation creates a force balance across the piston.

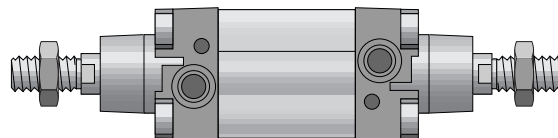

Figure 76: Through rod

### MULTI POSITION

By fixing two or more cylinders together and fully instroking or outstroking them in all the possible combinations, the attached load can be moved to a number of fixed reliable positions (Figure 77).

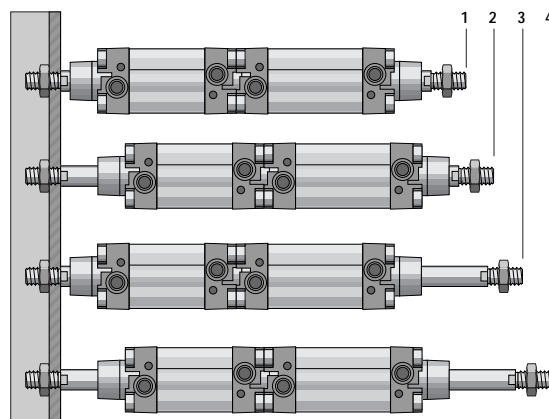

Figure 77: Two cylinder multi position

### TANDEM

This arrangement is used to double the pull and nearly double the thrust for a cylinder of a given bore size. It is suitable as an alternative to a larger bore cylinder when there is plenty of space available for length but restricted width and height. The construction is two cylinders joined end to end sharing a combined central end cover and a common piston rod (Figure 78). Air to drive both cylinders together is fed from either a



single direction control valve or a pair of valves when there is insufficient flow from one. Care would be needed to ensure that the higher max thrust that is developed is within the limits for rod buckling.

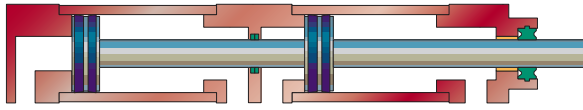

Figure 78: Tandem cylinder

## DUPLEX

This design is similar in construction to a tandem cylinder except that the piston rods are not joined and the rear most cylinder is of a shorter stroke. Nearly double the starting thrust is achieved and maintained throughout the stroke of the shorter cylinder, from there on the longer cylinder carries on at normal thrust. Uses include setting an intermediate position by operating the short cylinder only. The longer cylinder can be operated from that point (Figure 79).

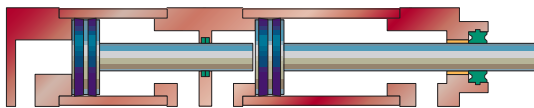

Figure 79: Duplex cylinder

## CUSTOM PISTON ROD END

Occasionally the device or mechanism that is to be connected to the cylinder's piston rod cannot be adapted to fit a standard piston rod end. In these cases a custom made piston rod can be specified. Typical arrangements include special thread forms, internal (female) threads and special thread lengths (Figure 80).

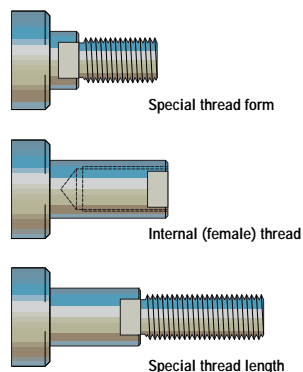

Figure 80: Three thread types

## EXTREME OPERATING TEMPERATURES

The seals are the components most affected by extreme ambient temperatures in which a cylinder is operating. High temperatures result in softening and rapid wear, low temperatures cause hardening and seal break up. Cylinders specially fitted with heat resistant or low temperature resistant seals can be specified. See the earlier section on seals.

## SPECIAL PURPOSE ACTUATORS

For specific applications there are cylinder types and ranges specially designed to meet these needs. These include double stroke cylinders, positioning cylinders, hollow rod cylinders and impact cylinders.

## DOUBLE STROKE CYLINDERS

To satisfy applications where a long reach is required, double stroke cylinders are available in rodless designs. Double stroke cylinders give twice the stroke of conventional cylinders of the same overall length. The double stroke is achieved by a belt running over pulleys at each end of the cylinder and is connected to both the powered carriage and the free carriage (the one not directly connected to the piston).

Two methods of operation can be achieved with this configuration.

By mounting the cylinder on the powered carriage, the free carriage will advance and, through the belt, will pull the cylinder body forward. This will give a stroke length twice that of a conventional rodless cylinder at the same length. It must be remembered that due to the mechanical advantage of doubling the stroke the thrust will be halved (Figure 81).

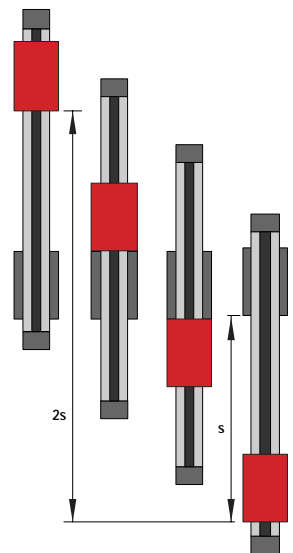

The other method of twin stroke design is to fix the body of the cylinder in a static position. When operated the two carriages will move in opposite directions, each giving a single stroke length (Figure 82).

Figure 81: Double stroke (fixed carriage design)

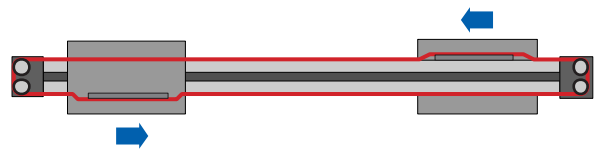

Figure 82: Twin stroke principle

## POSITIONERS AND SERVO CYLINDERS

A positioner cylinder is controlled from a servo valve and can move to any stroke position. This position is maintained even under changing load conditions. The servo valve receives an analogue instrument control signal in the range (0.2 to 1 bar or 0.2 to 2 bar pneumatic) or (4 to 20mA electronic) which determines the percentage of piston rod stroke in proportion to the signal. If the load applied to the piston rod changes, the servo valve will change the pressure conditions within the cylinder to ensure that the position is maintained. As soon as the control signal changes, the servo valve will adjust the pressures to bring the piston rod to the new proportional position.

### OPEN LOOP APPLICATIONS

An open loop system is where the control signal is derived independently, and is free from any automatic feedback link to the process it is controlling. For example, a servo cylinder is operating a butterfly valve (Figure 83). The control signal is set manually with a precision pressure regulator. The positioner will move to an angle of opening and hold it in proportion to the control signal. In this type of application the pressure gauge showing the control signal is often recalibrated to display the angle of opening of the butterfly valve. This allows the operator to set any valve opening and know that it will be reliably held in that position.

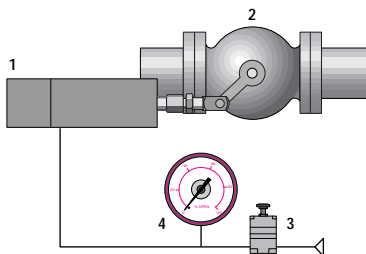

Figure 83: Open loop

Key:

1 Positioner	3 Precision pressure regulator
2 Butterfly valve	4 Pressure gauge

### CLOSED LOOP APPLICATIONS

A closed loop system is where the result of a process is continuously monitored and any deviations from the desired state are fed back to effect correction. In this example also, the positioner is controlling a butterfly valve (Figure 84). The valve is supplying cooling water to a heat exchanger for a liquid product. It is the temperature of the product that must be held constant not the angle of the valve. If the temperature of the product starts to increase, the temperature transmitter will increase its control signal. This will cause a corresponding increase in the angle of the valve, so supplying more cooling water to bring the temperature down. Conversely if the temperature of the product began to drop, the temperature

transmitter will reduce the control signal. This will reduce the angle of butterfly valve opening so supplying less cooling water. In operation the positioner is continuously making fine adjustments to the valve angle to maintain a near constant product temperature.

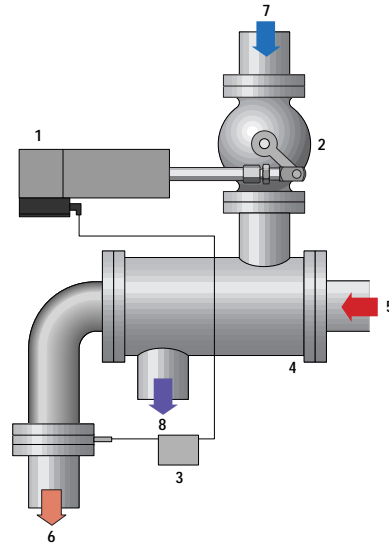

Figure 84: Closed loop control

Key:

1 Positioner	5 Hot liquid in
2 Butterfly valve	6 Cooled liquid out
3 Temperature transmitter	7 Cooling water in
4 Heat exchanger	8 Cooling water out

### IN-LINE POSITIONERS

These are fixed range devices with a choice of two bore sizes 2 1/2" and 4", each available in six stroke lengths from 75mm to 320mm.

Typical applications are the remote positional operation of dampers, variable speed gear boxes, burners, engine speed and power control, and quarter turn valves such as butterfly valves. In this design a low friction double acting cylinder, has a 5 port proportional flow servo valve mounted integrally in line with its rear end cover. Feedback of the piston rod position to the servo valve is force balance. This is from a tension spring located within the hollow piston rod (Figure 85). The analogue input control signal can be manually set or automatic. It can remain at any particular setting or can be continuously variable, within the response rate of the positioner system. The position of the piston rod within its stroke will always follow in proportion to the value of the control signal.

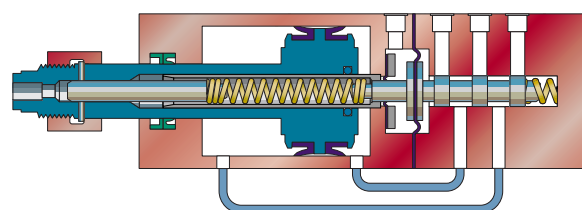

Figure 85: Fixed range positioner

On the pneumatically controlled model, if the signal pressure at the control port (12) is increased to a higher set value, the control diaphragm and spool assembly is displaced to the right. Controlled flow of main air is supplied to the rear of the piston whilst the front side is under controlled flow to exhaust. The piston starts moving to the left and the feedback spring is extended, so exerting a counter acting force on the diaphragm and spool assembly. This progressively increasing counter acting force allows the spool to move towards the centre position. so gradually closing down the rate of flow in to and out of the cylinder. When the piston and rod have achieved a position proportional to the value of the control signal, the force exerted by the spring exactly balances the force created by that control signal. At this condition of balance the spool is centred and blocks flow in and out of the cylinder so locking the pressure conditions and stabilising position. Any change to the control signal, higher or lower, will upset the force balance on the spool. This will cause the spool to move to the right or left so increasing or decreasing the stroke of the cylinder until a new position is found that restores the force balance and centre position of the spool. The resulting new position will be in proportion to the new control signal. For any given held control signal, the slightest drift caused by changes in load, will cause a corresponding change in the spring force and spool position. This allows air flow across the valve until the position has been restored again. The position of the cylinder can be continuously changed by continuously changing the control signal. Within the response time limits of the system the position of the piston rod will follow the time/signal characteristics of the control signal. The maximum response time is 10 seconds for a full 200mm stroke change or 50 ms/mm. On the electronically controlled model the positioner cylinder is fitted with an I/P (current to pressure) converter. This device converts the incoming 4 to 20 mA control signal to a 0.2 to 1 bar control signal directly connected to the servo valve. For both types, should the control signal fail to zero pressure or zero current, the cylinder will automatically return to an instroked position.

## SERVO CYLINDERS

There are many applications that require a positional cylinder of a larger bore and with a stroke outside the range of the in line models. To satisfy these applications servo cylinders can be used. They are available in a choice of two types the M/30000 series in three bore sizes 63, 80 and 100mm (Figure 86), and the M/29000 series in eight bore sizes from 2" to 12" (Figure 87). Either type is available in any stroke from 50 to 1000mm. Applications include open and closed loop process control in power stations, chemical plants, gas works, sugar refineries, paper mills, textile industries, steel works, air conditioning, and water purifying.

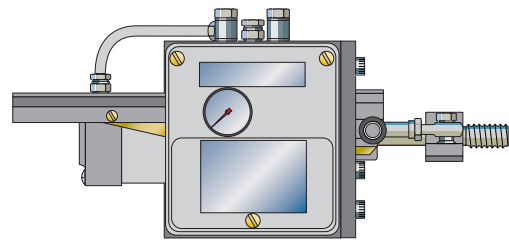

Figure 86: M/30000 detail

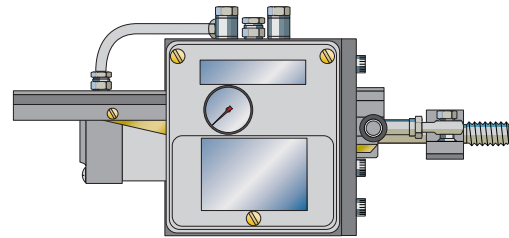

Figure 87: M/29000 detail

A servo-cylinder assembly consists of a universal position controller mounted on a low friction double acting cylinder, fitted piping and positional feedback mechanism linking the controller to the piston rod. Two controllers are available type M/1841 receiving a 0.2 bar to 2 bar control signal and type M/1842 receiving a 0.2 bar to 1 bar signal. Whichever one is chosen, the full range of the signal gives a corresponding proportional full range of the stroke of the cylinder. For any given stable signal, the proportional position of the piston rod will be held and is self compensating for changes in load applied to the piston rod. For open loop applications, the control signal can be generated manually from a precision regulator or applied automatically with preset values or a particular signal profile. Most applications however are closed loop. These connect to a transmitting instrument generating a control signal in proportion to some condition such as temperature, weight or displacement.

## UNIVERSAL POSITIONER

The universal positioner is the controller that mounts on the cylinder. This consists of a proportional flow servo valve, control signal actuating bellows, monitoring pressure gauges and a mechanical feedback mechanism. Adjustments are possible for zero position and proportional band. When looking at the piston rod end of the cylinder, the controller and feedback mechanism can be specified as left or right hand mounted. This is for convenience of viewing the pressure gauges.

The working principles of the controller and cylinder system can be seen from the illustration (Figure 88).

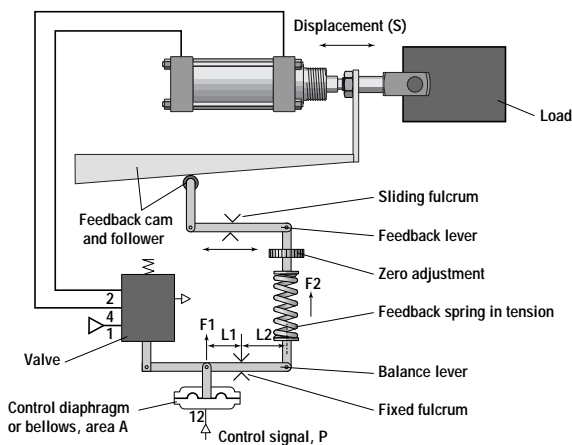

Figure 88: Universal positioner

The piston is holding a part stroked position. This means that the servo valve's spool is centred to stop air flow in or out of the cylinder. The centre position of the spool is achieved by a balance of forces on the balance lever. On one side of the fulcrum is the pushing force applied by the control signal through the bellows. On the other side is the pulling force from the feedback tension spring. The spring is tensioned by the feedback lever. The further outstroked the cylinder the greater the tension. Feedback is derived from a wedge shaped feedback cam attached to the cylinder's piston rod. As the rod outstrokes or instrokes, so the roller follower displaces one end of the feedback lever to increase or decrease tension in the spring. If the control signal pressure is increased, the balance lever will initially push the valve spool in. This will deliver more air to the rear of the cylinder and vent some from the front. As a result the piston rod will move in the outstroked direction. As it does so the cam follower pushes on the feedback lever so increasing the tension in the feedback spring. The balance lever is now being pulled back and the valve spool progressively backs off slowing the change of movement in the cylinder. At the point where the balance of forces on the balance lever is restored the valve spool will again be in the centre and the cylinder will stop.

If the control signal pressure is reduced, the balance lever will pull the valve spool out. This will deliver more air to the front of the cylinder and vent some from the back. As a result the cylinder will move in the instroked direction. As it does so the cam follower will progressively relax the tension in the spring and restore the balance of forces to the balance lever. As this happens the spool moves towards its centre position so slowing the movement of the cylinder. At the point where the balance of forces is restored the spool will be centred and the cylinder will stop. For every value of control pressure there will be a corresponding proportional position of the cylinder that will produce a balanced stable position.

From a stable position, the smallest change of displacement will be transmitted to the valve spool. Displacement may be brought about by an increase or decrease of axial load on the piston rod. This will cause a movement of the spool which will continue to change the pressure balance until the position of the cylinder is restored.

The lift of the cam over the full stroke of the piston rod, is the same for all stroke lengths. Long stroke cylinders will have a long cam with a shallow angle. Short stroke cylinders will have a short cam with a steep angle.

Zero adjustment is possible by altering the initial tension in the spring. This enables an installed cylinder to have a starting point that may not be the fully instroked position. Adjustment is in the range -50% of stroke to +50% of stroke illustrated by the graph (Figure 89).

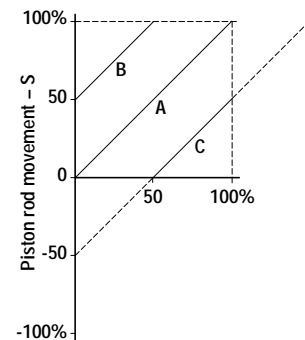

Proportional band is the percentage of stroke that the full signal range will give. It is adjustable between 25% and 150% as shown on the graph (Figure 90).

Figure 89: Zero adjustment graph

Adjustment is by setting the sliding fulcrum on which the feedback lever pivots.

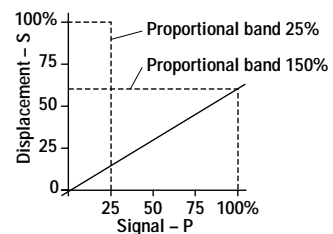

A servo cylinder can be assembled to act in reverse. This will give a fully outstroked position for the minimum control signal and a fully instroked position for a maximum control signal. This is achieved by swapping the front and rear cylinder pipe connections and turning round the feedback wedge cam.

Figure 90: Proportional band graph

For very special applications proportional control can be replaced by a customised characteristic. This is achieved by specially shaping the feedback cam to the characteristic required.

## HOLLOW PISTON ROD CYLINDERS

In many mechanical handling applications which involve pick and place systems and robotic arms, vacuum cups are used as end effectors. A neat method of advancing and retracting the vacuum cup as well as integrating it to the vacuum system is to attach it to the rod end of a pneumatic cylinder with a hollow piston rod. The rear end of the cylinder is threaded to connect to a switchable vacuum line. This is ducted down the internally telescopic piston rod to the vacuum cup (Figure 91). This feature could alternatively connect to a pressure source and service a single acting pneumatic gripper fitted to the end of the piston rod.

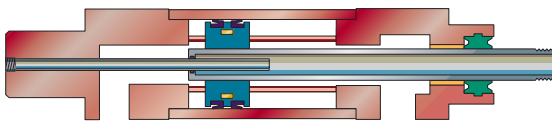

Figure 91: Hollow rod cylinder

## IMPACT CYLINDERS

The impact cylinder is designed to accelerate the piston and rod very rapidly and deliver a hammer blow. By fitting suitable tooling to the piston rod, the impact cylinder can carry out certain types of presswork that would otherwise require substantially larger and more costly presses.

Impact cylinders are given energy ratings in Nm. The larger the impact cylinder and the higher the operating pressure, the higher will be the energy rating. The energy rating of the hammer blow represents a force/distance potential. The shorter the distance through which work is performed, the higher will be the average force during that work. It is therefore short stroke applications that are best suited to an impact cylinder, they include shearing, blanking, punching, piercing, coining, cold forming, embossing, stamping, staking, marking, rivetting, swaging, bending, nailing, flattening, cropping, hot forming, crimping, and flying shear.

**Warning:** *There will be a pause before an impact cylinder fires. Also it is possible to hold an impact cylinder in balance at the point of firing, then vibration, extra load, a very slight change in the pressure balance or other disturbance will set it off. The working area should be guarded at all times and an indicator installed to warn when the top reservoir is charged.*

Bore sizes range from 2" to 6" diameter which can give an average equivalent thrust of 25 kN to 253 kN, when working through material of 1.0mm thickness, at 5.5 bar gauge working pressure. Materials of construction are steel barrel, die cast end covers and high tensile steel piston and rod. The piston is shrunk onto the piston rod to ensure a bonded joint that will withstand the repeated shock of each impact.

The energy rating for each size of cylinder is shown (Figure 92). The values are for air pressure at 5.5 bar and a free running piston rod with no additional guide friction.

Cylinder	Bore (inch)	Energy rating	
		Nm	Ft/lb
M/3020	2	25	18
M/3030	3	63	46
M/3040	4	126	93
M/3060	6	253	186

Figure 92: Energy ratings

Adding mass to the piston rod will not necessarily reduce the energy developed but there will be a trade off against peak velocity. The energy output from an impact cylinder can be controlled by adjusting the air pressure.

## PRINCIPLE OF OPERATION

The impact cylinder is able to accelerate the piston and rod rapidly for two reasons.

One, before the piston moves, the air under the piston is allowed to almost completely pre-exhaust.

Two, before the piston moves, a charge of compressed air is allowed to build up on top of the piston.

The impact cylinder has an orifice plate fixed at approximately one third of the barrel length from the rear end cover. This acts as an end stop for the piston. The orifice has a raised circumferential seating ring which seals with a flat sealing disc in the end of the piston. This forms a large diameter poppet valve where the piston is the poppet. The cylinder is operated from a 5/2 valve in the same way as a conventional cylinder. When the impact cylinder is instroked, line pressure will be under the piston holding it in position so closing the poppet (Figure 93).

When the control valve is operated the chamber on top of the piston is pressurised and the volume under the piston is vented. The area ratio of the poppet orifice to the annular area under the piston is approximately 1 to 9. This means that the pressure ratio in the cylinder must be more than 9 on top of the piston, to 1 under the piston, before the piston

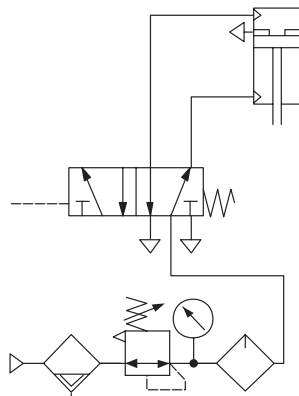

Figure 93: Impact cyl and valve

can start moving. This gives a slight pause after operating the control valve while the pressures are attaining this ratio. At a line pressure of 5.5 bar the pressure under the piston must drop to below 0.6 bar before the piston starts to move. As soon as it does so the poppet valve is open and the effective area presented to the charged volume on top is instantly expanded by nine times. This sudden application of force coupled with very little back pressure under the piston gives rise to the rapid acceleration. If the cylinder is freely operated it will reach a max velocity at about 75mm of stroke and then completely cushion itself. The cushion is created by the small amount of air that remains under the piston. This is compressed at a faster rate than it can escape through the port in the front end cover. This cushioning effect is useful to have for a cylinder that is fired freely, otherwise it would destroy itself. In most applications however, the piston and rod will be brought to a dead stop by the tooling at the end of the working stroke. The graph (Figure 94) shows typical kinetic energy characteristics of the

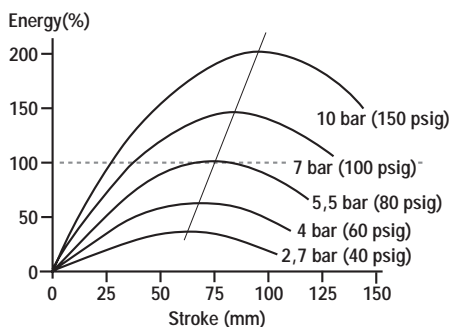

Figure 94: Energy graph

piston and rod against stroke at varying line pressures.

The firing of an impact cylinder is illustrated in three stages showing the cylinder only (Figure 95).

Stage 1. The control valve is in its normal state, directing air pressure to the front end of the cylinder holding the piston instroked with the rear end exhausted. The flat seat in the end of the piston is sealed. The small annular volume between the poppet seat and the top piston lip seal is vented to atmosphere through a small hole in the bleed plug.

Stage 2. The control valve has operated and switches air pressure to the rear end of the cylinder and exhausts the front end. Movement will not take place immediately because the pressure differential has to reach beyond the 9 : 1 balance of forces ratio.

Stage 3. The continued change in pressure differential has produced enough force to move the piston off the seat. This has suddenly exposed the full area of the top of the piston to the fully charged top reservoir. Because the pressure in the front of the cylinder is now very low, the piston and rod assembly accelerate extremely rapidly, reaching a peak velocity and energy at between 50mm and 75mm of stroke. On completion of the work, the control valve can be reset and the cylinder will return to the conditions in stage 1.

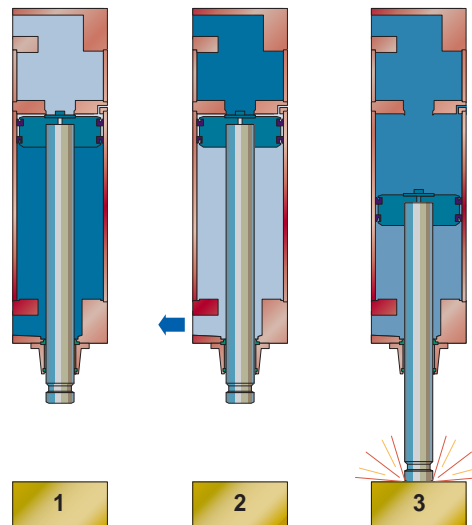

Figure 95: Three stages of operation

## INSTALLATION

Although an impact cylinder can be used in any attitude, generally fewer problems are involved when it is used to impact vertically up or vertically down. At the point of impact the piston rod and tooling could be considered to be in free flight so the reaction between the top and bottom plates of a mounting frame will be only the thrust developed over the piston area by the air pressure on top of the piston. The frame, however, must be stiff enough to take the recoil force generated in the cylinder's body at the instant of firing. This can be enough to lift a light weight frame, and makes it necessary to either fix the frame to a heavy bench or separate stand, or make the frame itself very heavy. The whole construction should be bolted to the floor. This is particularly important when using the larger impact cylinders. The installation may

otherwise walk when operated repeatedly. Frames should be fabricated from flame cut steel and welded. Any butt joints in the frame or stand should be in compression not shear. Lightweight cast frames must not be used as there will be a danger of them failing due to shock fatigue.

Four pillar frames are the most economical to construct and in their simplest form consist of two plates separated by four pillars (Figure 96). A thick top plate will give better resistance to flexing when the cylinder is fired and will have the advantage of adding mass to the cylinder body.

To form a combined four pillar frame and tool set, precision pillars can be used with a third plate moving on ball cage or plain bearings and attached to the piston rod. Due to the rapid acceleration imposed, the moving plate and tooling should be dynamically balanced about the attachment point of the piston rod. For example fixing the piston rod to a rear pillar die-set will give offset frictional resistance and is likely to jam on firing the cylinder.

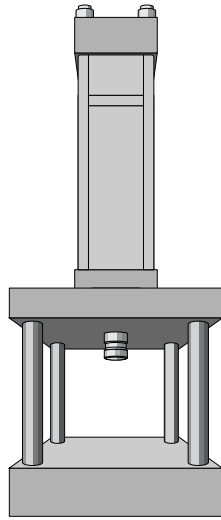

Figure 96: Four pillar frame







