

**Compact Cylinders**  
**Magnetic Piston**  
**Single Acting**  
 Ø 12 to 63 mm

- **Very compact – approximately one third the basic length of a corresponding ISO model**
- **Entirely manufactured from non-corrodible materials**
- **Magnetic piston as standard provides a wide range of control options**



### Technical Data

Medium:

Compressed air, filtered, lubricated or non-lubricated

Operation:

RM/91000/M Single acting, non-cushioned, magnetic, sprung in

RM/93000/M Single acting, non-cushioned, magnetic, sprung out

Operating Pressure:

2 to 10 bar

Operating Temperature:

-5°C\* to +80°C

\*Consult our Technical Service for use below +2°C

Cylinder Diameters:

12, 16, 20, 25, 32, 40, 50, 63 mm

Standard Strokes:

5 mm Ø 12 to 25 mm

10 mm Ø 12 to 63 mm

25 mm Ø 32 to 63 mm

Non-standard Strokes:

Non-standard strokes available

10 mm max. Ø 12 and 16 mm

50 mm max. Ø 20 to 63 mm

Materials:

Anodised aluminium alloy barrel and end caps, stainless steel (Ø 12 to 40 mm Austenitic, Ø 50 and 63 mm Martensitic) piston rod, polyurethane and/or nitrile rubber seals

### Alternative Cylinders:

See page N 1.4.091.02

### Ordering Information

To order a basic 63 mm bore cylinder, sprung in with a 25 mm stroke and magnetic piston quote: RM/91063/M/25

To order a basic 16 mm bore cylinder, sprung out with a 5 mm stroke and magnetic piston quote: RM/93016/M/5

To order mounting brackets refer to appropriate cylinder mounting table.

Order magnetically operated switches separately.

### Accessories

See page

Switch M/40

N 4.3.041.01

Switches M/41, M/42

N 4.3.043.01

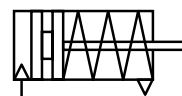

Magnetic, sprung in

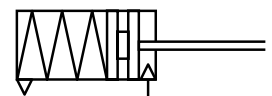

Magnetic, sprung out

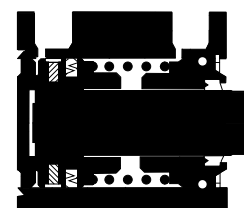



## Alternative Cylinders

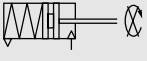



Symbol	Model (magnetic piston)	Description
	RM/91000/N2	Non-rotating piston rod (∅ 16 to 63 mm), sprung in
	RM/93000/N2	Non-rotating piston rod (∅ 16 to 63 mm), sprung out

## Theoretical Forces • Air Consumption • Torque for Cylinders RM/91000/N2 and RM/93000/N2

∅	RM/91000/M Theoretical forces (N) at 6 bar		RM/93000/M Theoretical forces (N) at 6 bar		Air consumption (l/cm stroke) at 6 bar		Torque max. (Nm)	
	Outstroke	F 1	Instroke	F 1	Outstroke	Instroke	Model	
12	57	7	40	7	0,008	0,006	-	-
16	103	12,5	72	12,5	0,014	0,011	RM/91016/N2, RM/93016/N2	0,15
20	161	14,5	119	14,5	0,022	0,017	RM/91020/N2, RM/93020/N2	0,25
25	264	20	197	20	0,035	0,027	RM/91025/N2, RM/93025/N2	0,40
32	432	32	311	32	0,056	0,042	RM/91032/N2, RM/93032/N2	0,75
40	687	44	566	44	0,088	0,074	RM/91040/N2, RM/93040/N2	0,75
50	1094	56,5	906	56,5	0,138	0,116	RM/91050/N2, RM/93050/N2	1,50
63	1770	74,5	1582	74,5	0,218	0,196	RM/91063/N2, RM/93063/N2	1,50

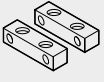
F1 = Return force of spring (N)

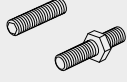
## Weights of Cylinders and Mountings (kg)

∅	Weight at 0 mm	Weight per 5 mm						
			Style 'B', 'G'	Style 'C'	Style 'F'	Nut	Stud or Adaptor	Assembly kit
12	0,070	0,020	0,020	0,020	0,010	0,001	0,001	0,020
16	0,090	0,020	0,020	0,020	0,010	0,001	0,002	0,022
20	0,120	0,020	0,020	0,020	0,010	0,001	0,003	0,026
25	0,170	0,030	0,040	0,040	0,010	0,002	0,005	0,035
32	0,280	0,050	0,060	0,040	0,020	0,003	0,010	0,045
40	0,440	0,060	0,150	0,100	0,020	0,003	0,010	0,120
50	0,500	0,080	0,170	0,110	0,040	-	0,020	0,125
63	0,900	0,110	0,330	0,130	0,090	-	0,035	0,270

## Warning

These products are intended for use in industrial compressed air systems only. Do not use these products where pressures and temperatures can exceed those listed under 'Technical Data'.

Before using these products with fluids other than those specified, for non-industrial applications, life-support systems, or other applications not within published specifications, consult NORGREN.

Through misuse, age, or malfunction, components used in fluid power systems can fail in various modes.

The system designer is warned to consider the failure modes of all component parts used in fluid power systems and to provide adequate safeguards to prevent personal injury or damage to equipment in the event of such failure.

**System designers must provide a warning to end users in the system instructional manual if protection against a failure mode cannot be adequately provided.**

System designers and end users are cautioned to review specific warnings found in instruction sheets packed and shipped with these products.



**Basic Dimensions**

**RM/91000/M**

**RM/93000/M**

(∅ 12 to 63 mm)

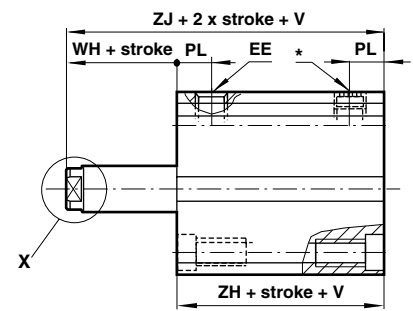
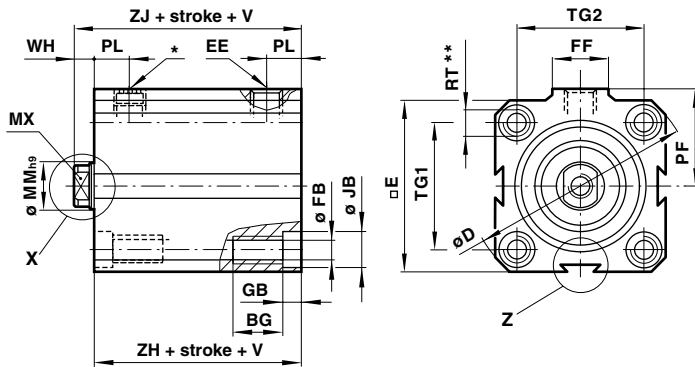

Section X

Section Z

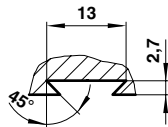
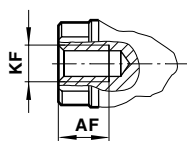

\* Port thread with inserted filter, do not obstruct.  
 \*\* Only the 4 front holes are tapped on stroke lengths of less than:  
 ∅ 25 and 32 mm: 5 mm, ∅ 40 and 63 mm: 15 mm (.../N2: 5 mm)  
 ∅ 50 mm: 10 mm  
**Note:** ∅ 12 to 20 mm feature only two side dovetails.

**Non-rotating piston rod RM/91000/N2**

**RM/93000/N2**

(∅ 16 to 63 mm)

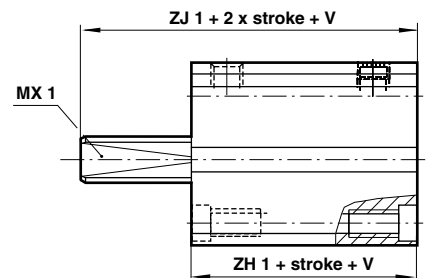
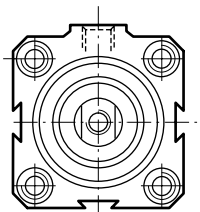
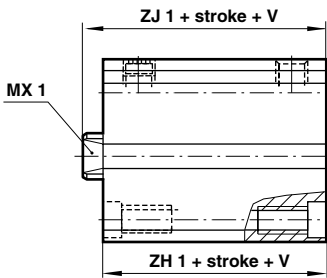

Model	91012, 93012	91016, 93016	91020, 93020	91025, 93025	91032, 93032	91040, 93040	91050, 93050	91063, 93063
∅	12	16	20	25	32	40	50	63
AF	6	7	8	9	12	12	14	16
BG	9	9	9	12	12	16	16	20
∅ D	32,5	36,5	41,5	48	58	71,5	81	104
□ E	25	28	32	37	45	55	63	80
EE	M 5	M 5	M 5	M 5	G 1/8	G 1/8	G 1/8	G 1/4
∅ FB	3,3	3,3	3,3	4,2	4,2	6,8	6,8	8,5
FF	10	10	10	10	18	18	18	22
GB	3,5	3,5	3,5	4,5	4,5	6,5	6,5	8,5
∅ JB	6	6	6	7,5	7,5	10,5	10,5	13,5
KF	M 3	M 4	M 5	M 6	M 8	M 8	M 10	M 12
∅ MM h9	6	8	10	12	16	16	20	20
MX (A/F)	5	6	8	10	13	13	17	17
MX 1 (A/F)	-	6	8	10	13	13	16	16
PF	15	17	19,5	22	27,5	31,5	37	48
PL	7	7,5	7,5	8	9	10	10,5	13
RT	M 4	M 4	M 4	M 5	M 5	M 8	M 8	M 10
TG 1	17	20	23	27	33	41	48	61
TG 2	13	20	23	27	33	41	48	61
V (strokes 0 to 25)	14	15	17	18	19	20	30	30
(strokes 26 to 50)	-	-	34	36	38	40	60	60
WH	4,5	5,5	6	6,5	6,5	6,5	8	8
ZH	24	24,5	26	28,5	29	31,5	35	42,5
ZH 1	-	34,5	36	38,5	39	41,5	45	52,5
ZJ	28,5	30	32	35	35,5	38	43	50,5
ZJ 1	-	40	42	45	45,5	48	53	60,5



**Rear Flange Mounting Style 'B'**  
**Front Flange Mounting Style 'G'**  
 RM/91000/M, RM/91000/N2

RM/93000/M, RM/93000/N2

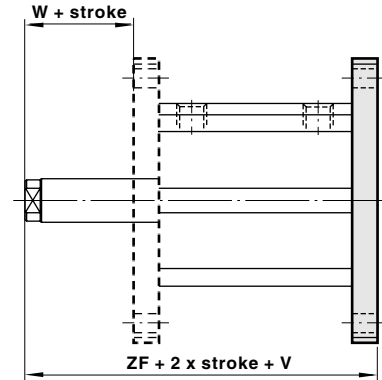
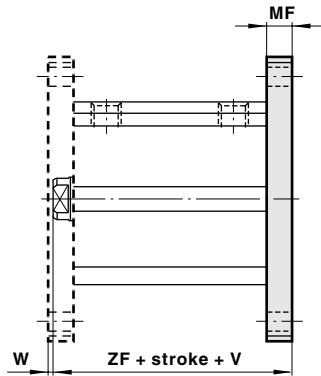
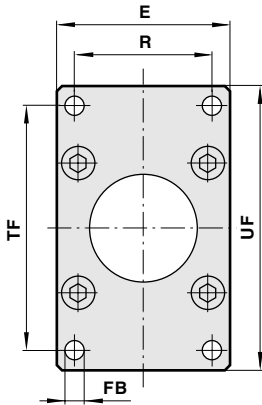

**Foot Mounting Style 'C'**  
 RM/91000/M, RM/91000/N2

RM/93000/M, RM/93000/N2

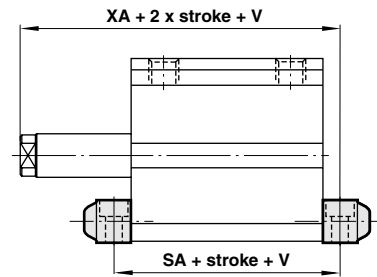
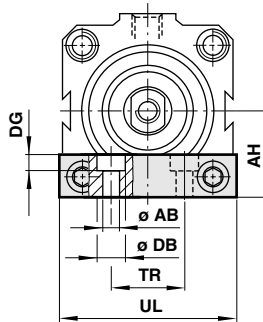
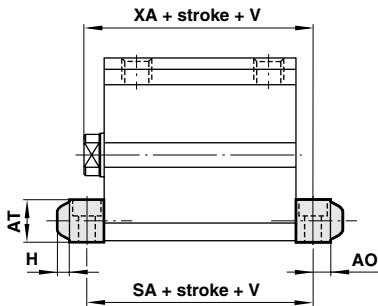

Model 'B', 'G'	QM/90012/22	QM/90016/22	QM/90020/22	QM/90025/22	QM/90032/22	QM/90040/22	QM/90050/22	QM/90063/22
Model 'C'	QM/90012/21	QM/90016/21	QM/90020/21	QM/90025/21	QM/90032/21	QM/90040/21	QM/90050/21	QM/90063/21
∅ AB	12	16	20	25	32	40	50	63
∅ AB	3,4	3,4	3,4	4,3	4,3	6,4	6,4	8,4
AH	13,5	15	16,5	20	24	28,5	32	41,5
AO	4	4	4	5	5	6,5	6,5	8
AT	9,5	9,5	9,5	12,5	12,5	16	16	22
∅ DB	6	6	6	7,5	7,5	10,5	10,5	13,5
DG	3,5	3,5	3,5	4,5	4,5	6,5	6,5	8,5
E	26	30	33	38	46	57	64	81
H	2	2	2	3	3	4,5	4,5	5,5
∅ FB	3,5	3,5	3,5	4,5	4,5	6,5	6,5	8,5
MF	5	5	5	6,5	6,5	9,5	9,5	12,5
R	18	22	25	28	36	43	50	63
TF	38	42	48	54	66	78	90	110
TR	25	32	35	41	19	21	27	34
UF	46	50	56	64	76	92	104	128
UL	33	40	43	51	46	56	64	81
V (strokes 0 to 25)	14	15	17	18	19	20	30	30
(strokes 26 to 50)	-	-	34	36	38	40	60	60
W	- 0,5	0,5	1	0	0	- 3	- 1	- 4,5
SA	32 (42)	32,5 (42,5)	34 (44)	38,5 (48,5)	39 (49)	44,5 (54,5)	48 (58)	58,5 (68,5)
XA	32,5 (42,5)	34 (44)	36 (46)	40 (50)	40,5 (50,5)	44,5 (54,5)	49,5 (59,5)	58,5 (68,5)
ZF	33,5 (43,5)	35 (45)	37 (47)	41,5 (51,5)	45 (55)	47,5 (57,5)	52,5 (62,5)	63,5 (73,5)

Note: Dimension 'W' negative figures indicate that the piston is proud of the mounting face.  
 ( ) = for non-rotating piston rod cylinders RM/91000/N2 and RM/93000/N2



### Piston Rod Clevis Mounting Style 'F'

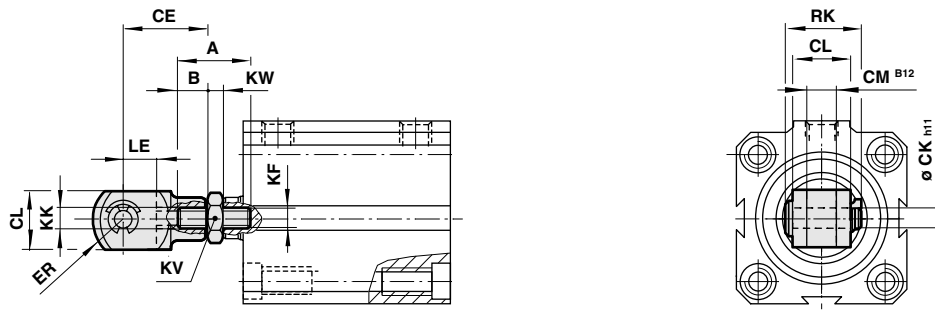

Model 'F'	QM/57008/25	QM/8010/25	QM/92020/25	QM/57016/25	QM/57020/25	QM/57025/25	QM/57040/25
Stud	M/P1710/18	M/P1710/19	M/P1710/20	M/P1710/21	M/P1710/22	-	-
Nut	M/P1500/111	M/P1501/80	M/P1501/109	M/P1501/79	M/P1501/60	-	-
Adaptor	-	-	-	-	-	M/P71470/1	M/P71470/2
∅	12	16	20	25	32 and 40	50	63
A	12	16	20	25	25	29	35
B	-	-	-	-	-	12	15
CE	11	16	20	20	24	26	40
∅ CK h11	3 h9	4	5	5	6	8	10
□ CL	6	8	10	10	12	14	20
CM B12	3	4	5	5	6	7	10
ER	4,5	6,5	8	8	9,5	11,5	16
KF	M 3	M 4	M 5	M 6	M 8	M 10	M 12
KK	M 3	M 4	M 5	M 6	M 8	M 10 x 1,25	M 12 x 1,25
KV (A/F)	6	7	8	10	13	12	13
KW	2	2	2,5	3	4	5	5
LE	5	8	10	10	12	12	20
RK	10	11,5	14,5	14,5	17,5	20,5	29

To order a piston rod clevis mounting style 'F' complete: ∅ 12 to 40 mm = Model 'F' plus Stud and Nut, ∅ 50 and 63 mm = Model 'F' plus Adaptor.

### Assembly kit

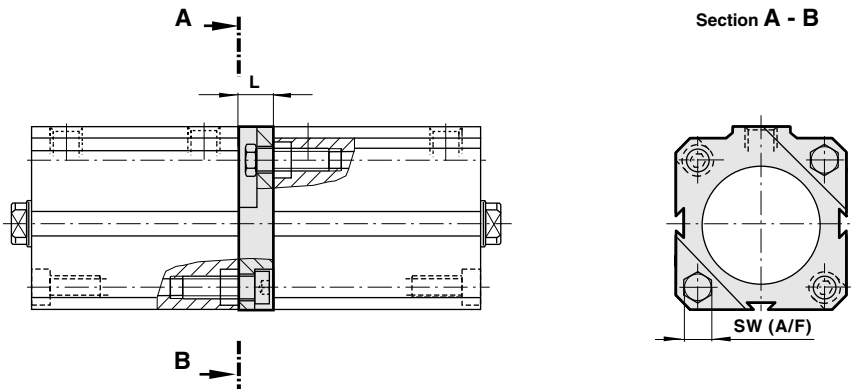

Assembly kit	QM/92012/55	QM/92016/55	QM/92020/55	QM/92025/55	QM/92032/55	QM/92040/55	QM/92050/55	QM/92063/55
∅	12	16	20	25	32	40	50	63
L	10	10	10	10	10	15	15	20
SW (A/F)	7	7	7	8	8	13	13	17



## Spares

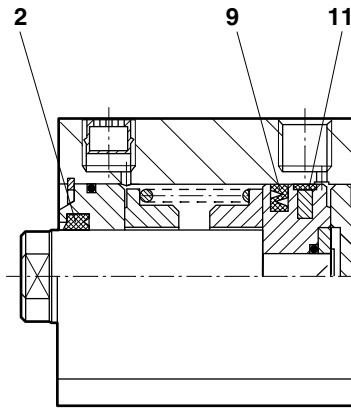

Model	Spares kit	Comprising Item	Description	Quantity
RM/91050/M, RM/93050/M	QM/92050/00	2	Piston rod seal	1
RM/91063/M, RM/93063/M	QM/92063/00	9	Piston seal	1
		11	Wear ring	1
			Grease	1

Note: Please quote the cylinder number when ordering spare parts.  
Spares are not available for  $\varnothing$  12 to 40 mm models.